



Corbettmaths

Ultimate
GCSE Foundation
Revision
Question Booklet

Revision Video



Answers



Contents

Words and Figures.....	5	Ordering Fractions.....	24
Addition.....	5	Adding Fractions	24, 25
Subtraction.....	6	Multiplying Fractions.....	25
Multiplication.....	6, 7	Dividing Fractions.....	26
Division.....	7	Reciprocals.....	26
Order of Operations.....	8	Fractions, Decimals, %.....	27
Rounding.....	8	Expressing as a Percentage.....	27
Rounding (Lowest/Highest).....	9	Percentages of Amounts (NC)....	28
Estimation.....	9	Percentages of Amounts.....	29
Ordering Decimals.....	10	Percentage Change.....	29
Arithmetic with Decimals.....	10, 11	Simple Interest.....	30
Negative Numbers.....	11	Multipliers.....	30
Negatives (add/subtract).....	12	Compound Interest.....	30
Negatives (multiply/divide).....	12	Reverse Percentages.....	31
Place Value.....	12	Simplifying Ratios.....	31
Inequality Sign.....	13	Ratio - 1:n	32
Place Value: Operations.....	13	Forming Ratio.....	32
Multiples.....	13	Ratio & Fractions.....	32
Common Multiples.....	13	Sharing in a Ratio.....	33
Factors.....	14	Ratio (one quantity).....	33
Common Factors.....	14	Two Ratios.....	33
LCM/HCF.....	14	Ratios and Equations.....	34
Prime Numbers.....	15	Unitary Method.....	34
Square Numbers.....	15	Exchange Rates.....	35
Squaring Numbers.....	15	Recipes.....	36
Square Roots.....	16	Proportion.....	36
Cube Numbers.....	16	Direct Proportion.....	37
Cube Roots.....	16	Inverse Proportion.....	37
Indices.....	17	Proportion Graphs.....	37
Laws of Indices.....	17	Proportion: Time.....	37
Negative Indices.....	18	Best Buys.....	38
Product of Primes.....	18	Money.....	38
Applying Product of Primes.....	19	Use of a Calculator.....	38
LCM/HCF (Product of Primes).....	19	Error Intervals.....	39
Standard Form.....	20, 21	Types of Angle.....	39
Fractions of Amounts.....	22	Drawing Angles.....	39
Expressing as a Fraction.....	22	Measuring Angles.....	40
Fractions of Shapes.....	23	Angle Facts.....	40, 41
Simplifying Fractions.....	23	Angles in a Triangle.....	41
Equivalent Fractions.....	24	Angles in a Quadrilateral.....	41

Angles (Polygons).....	42	Parts of a Circle.....	63
Angles in Parallel Lines.....	43	Circumference.....	63
Scales.....	43	Perimeter of a Semi-Circle.....	64
Maps.....	43	Arc Length.....	64
Compass Directions.....	44	Area of a Circle.....	65
Bearings.....	44, 45	Area of a Semi-Circle.....	65
Back Bearings.....	45	Area of a Sector.....	66
Perimeter on a Grid.....	45	Pythagoras.....	66, 67
Perimeter.....	46	Trigonometry.....	67, 68
Area on a Grid.....	46	Exact Trig Values.....	68
Area of a Rectangle.....	46	Similar Shapes.....	69
Area of a Triangle.....	47	Congruent Shapes.....	69
Area of a Parallelogram.....	47	Congruent Triangles.....	70
Area of a Trapezium.....	47	Volume of a Cuboid.....	70
Area of Compound Shapes.....	48	Volume of a Prism.....	71
Units.....	48, 49	Volume of a Cylinder.....	71
Sensible Estimates.....	49	Volume of a Cone.....	72
Imperial Units.....	50	Volume of a Pyramid.....	72
Line Symmetry.....	50	Volume of a Sphere.....	73
Rotational Symmetry.....	50	Surface Area.....	73
Constructions.....	51	Surface Area of a Sphere.....	74
Loci.....	52	Surface Area of a Cone.....	74
2D Shapes.....	52	Units (Area/Volume).....	75
Types of Triangle.....	53	Column Vectors.....	75
Quadrilaterals.....	53	Vectors.....	75
3D Shapes.....	54	Writing Expressions.....	76
Edges, Faces, Vertices.....	54	Collecting Like Terms.....	76
Nets.....	55	Multiplying Terms.....	77
Parallel/Perpendicular Lines.....	55	Laws of Indices.....	77
Views and Elevations.....	56	Expanding Brackets.....	77, 78
Time Calculations.....	57	Expanding 2 Brackets.....	78, 79
Timetables.....	57	Factorisation.....	79
Distance Charts.....	58	Factorising Quadratics.....	80
Speed, Distance, Time.....	58, 59	Solving Quadratics.....	81
Distance-Time Graphs.....	59	Difference Between 2 Squares.....	81
Density.....	60	Substitution.....	82
Pressure.....	60	Solving Equations.....	82, 83
Translations.....	61	Letters Both Sides.....	84
Rotations.....	61	Forming Equations.....	84
Reflections.....	62	Solving Inequalities.....	85
Enlargements.....	62	Inequalities (number line).....	85, 86

Changing the Subject.....	86	Scatter Graphs.....	112
Identities.....	87	Stem-and-Leaf Diagrams.....	112
Function Machines.....	87	The Mode.....	113
Coordinates.....	87	The Median.....	113
Drawing Linear Graphs.....	88	The Mean.....	113
Midpoint of a Line.....	89	The Range.....	113
Length of a Line.....	89	Mode from a Frequency Table.....	114
Graphical Solutions.....	90	Mean from a Frequency Table.....	114
Gradient.....	91	Median from a Frequency Table.....	115
Equation of a Line.....	92, 93	Estimated Mean.....	115
Parallel Lines.....	94	Modal Class.....	116
Real-Life Graphs.....	94	Class Containing the Median.....	116
Conversion Graphs.....	95	Combined Mean.....	117
Quadratic Graphs.....	96	Venn Diagrams.....	117, 118
Solving Quadratics Graphically.....	97	Tree Diagrams.....	119
Reciprocal Graphs.....	97	Reading Tables.....	120
Cubic Graphs.....	98	Samples.....	120
Sequences.....	99		
Triangular Numbers.....	99		
Generating Sequences.....	100		
Patterns.....	100		
Fibonacci.....	100		
The nth Term.....	101		
Arithmetic/Geometric.....	101		
Simultaneous Equations.....	102		
Tally Charts.....	103		
Frequency Trees.....	103		
Two-Way Tables.....	104		
Pictograms.....	104		
Bar Charts.....	105		
Dual Bar Charts.....	105		
Composite Bar Charts.....	106		
Frequency Polygons.....	106		
Line Graphs.....	107		
Pie Charts.....	108		
Probability Scale.....	109		
Probability.....	109		
Not Happening.....	110		
Relative Frequency.....	110		
Listing Outcomes.....	111		
Sample Spaces.....	111		

Words and Figures - [Videos 362, 363](#)

1. Write the number 981 in words.

.....

2. Write the number 3104 in words.

.....

3. Write the number **eighteen thousand and thirty-two** in figures

.....

4. Write the number **nine million** in figures

.....

Addition - [Video 6](#)

5. Work out $345 + 77$

.....

6. Find the sum of 522 and 193

.....

Subtraction - [Video 304](#)

7. Find the difference between 85 and 26

.....

8. Work out $415 - 132$

.....

Multiplication - [Video 200](#)

9. Work out 17×8

.....

10. Find the product of 126 and 5

.....

11. Shannon does 15 press-ups each day in January.
Work out how many press-ups Shannon does in January.

.....

Division - [Video 98](#)

12. Work out $426 \div 3$

.....

13. 288 guests attend a wedding.
Each table at the wedding will sit 8 guests.
How many tables are needed?

.....

14. A group of 12 friends share £192 equally.
How much money does each friend get?

.....

Order of Operations - [Video 211](#)

15. Calculate the value of $75 - 15 \times 3$

.....

Rounding - [Videos 276, 277a, 277b, 278, 279a](#)

16. Round 64 to the nearest ten

.....

17. Round 752kg to the nearest hundred kilograms.

.....

18. Round £128.32 to the nearest £10

.....

19. Round 9311 to the nearest 100

.....

20. Round 47638 days to the nearest thousand days

.....

21. Round 5.27 to the nearest tenth

.....

22. Write 1373 correct to 1 significant figure

.....

Rounding (Highest/Lowest) - [Video 280](#)

There are 300 jelly beans in a jar to the nearest hundred.

23. Write down the lowest possible number of jelly beans in the jar.

.....

24. Write down the greatest possible number of jelly beans in the jar.

.....

Estimation - [Video 215](#)

25. A school hall has 18 rows of 31 chairs.

Estimate how many chairs there are.

.....

26. Estimate the value of $\frac{49.1 \times 40.4}{9.05 - 5.1}$

.....

Ordering Decimals - [Video 95](#)

27. Arrange in order, starting with the smallest.

6.25 6.2 6.18 6.08 6.1

.....

28. Arrange in order, starting with the largest.

2.21 2.3 2.029 2.15 2.136

.....

Arithmetic with Decimals - [Videos 90, 91, 92, 93, 94](#)

29. Work out $6.15 + 2.47$

30. Work out $7.3 - 2.54$

.....

31. Work out 0.9×0.2

.....

.....

32. Work out $74.5 \div 5$

.....

33. Work out $14 \div 0.2$

.....

Ordering Negative Numbers - [Video 208](#)
Real-Life Negatives - [Video 209](#)

34. Arrange these temperatures in order, starting with the coldest.

-6°C , -3°C , 11°C , -8°C , 2°C

.....

35. Shown below are the elevations of 6 locations.

Location	Elevation
Coachella	-22 metres
Bern	542 metres
Jericho	-258 metres
Baku	-28 metres
Lake Eyre	-16 metres
Tokyo	17 metres

Which location has the lowest elevation?

.....

Addition & Subtraction involving Negative Numbers - [Video 205](#)

36. $3 - 5 =$

37. $-4 + 10 =$

38. $-20 - 3 =$

39. $9 + (-2) =$

40. $4 - (-2) =$

41. $-8 + (-3) =$

Multiplication & Division involving Negative Numbers - [Videos 206, 207](#)

42. $6 \times -2 =$

43. $-5 \times 5 =$

44. $-10 \times -3 =$

45. $-32 \div -4 =$

46. $-18 \div 2 =$

47. $49 \div -7 =$

Place Value - [Video 222](#)

48. Write down the value of the digit 6 in the number 5619

.....

49. Write down the value of the digit 2 in the number 1.28

.....

Inequality Sign - [Video 176](#)

50. Write the correct symbol, > or < in each box to make the statement correct.

91 96

146 142

0.5 0.39

Place Value (using calculations) - [Video 222a](#)

Given that $83 \times 177 = 14691$

51. Write down the answer to $14691 \div 177$

.....

52. Write down the answer to 830×1770

.....

Multiples - [Video 220](#)

53. List the first ten multiples of 3

.....

54. List the first five multiples of 15

.....

Common Multiples - [Video 218](#)

55. Write down three common multiples of 4 and 6

.....

Factors - [Video 216](#)

56. List the factors of 18

.....

57. List the factors of 40

.....

Common Factors - [Video 219](#)

58. Find the common factors of 16 and 20

.....

LCM/HCF - [Videos 218, 219](#)

59. Find the lowest common multiple of 12 and 15

.....

60. Find the highest common factor of 18 and 45

.....

Prime Numbers - [Video 225](#)

61. Is 15 a prime number? Yes No
62. Is 13 a prime number? Yes No
63. List the first 5 prime numbers
-
-

Square Numbers - [Video 226](#)

64. Is 36 a square number? Yes No
65. Is 10 a square number? Yes No
66. List the first 10 square numbers
-
-

Squaring Numbers - [Video 227](#)

67. Work out 20^2

.....

68. Calculate 37^2

.....

Square Roots - [Video 228](#)

69. Find the square root of 81

.....

70. Calculate $\sqrt{1225}$

.....

Cube Numbers - [Videos 212, 213](#)

71. Is 100 a cube number?

Yes

No

72. Is 64 a cube number?

Yes

No

73. List the first 5 cube numbers

.....

Cube Roots - [Video 214](#)

74. Find the cube root of 27

.....

75. Calculate $\sqrt[3]{8000}$

.....

Indices - [Video 172](#)

76. Work out 2^4

.....

77. Calculate 9^4

.....

78. Write $6 \times 6 \times 6 \times 6 \times 6$ in index form

.....

Laws of Indices - [Video 174](#)

79. Write $2^3 \times 2^5$ in the form 2^n

.....

80. Write $5^{10} \div 5^2$ as a single power of 5

.....

81. Write $(10^6)^2$ in the form 10^n

.....

Negative Indices - [Video 175](#)

82. Work out 5^{-2}

.....

83. Work out 10^{-3}

.....

Product of Primes - [Video 223](#)

84. Write 20 as a product of primes.
Give your answer in index form.

.....

85. Write 48 as a product of primes.
Give your answer in index form.

.....

86. When a number is written as a product of primes, the answer is $2^2 \times 3^2 \times 5$
What was the number?

.....

Applying Product of Primes - [Video 223a](#)

87. A number, y , written as a product of primes is 5×7^2
Write the number $14y$ as a product of primes.

.....

88. Given that $120 = 2^3 \times 3 \times 5$

Find the lowest whole number that 120 would need to be multiplied by to give a cube number.

.....

Product of Primes - LCM/HCF - [Video 224](#)

89. Find the HCF and LCM of 48 and 60

HCF =

LCM =

Standard Form - [Videos 300, 301, 302, 303](#)

90. Write 700000 in standard form

.....

91. Write 28000 in standard form

.....

92. Write 0.094 in standard form

.....

93. Write 1.7×10^4 as an ordinary number

.....

94. Write 9.2×10^{-3} as an ordinary number.

.....

95. Write 450×10^5 in standard form.

.....

96. Work out $(3.8 \times 10^5) + (1.9 \times 10^6)$

.....

97. Work out $(6 \times 10^3) \times (4 \times 10^5)$
Give your answer in standard form.

.....

98. Work out $(4 \times 10^9) \div (5 \times 10^{-2})$
Give your answer in standard form.

.....

Fractions of Amounts - [Video 137](#)

99. Work out $\frac{3}{4}$ of 200

.....

100. There are 30 students in a class
 $\frac{2}{5}$ of the students cycle to school

How many students cycle to school?

.....

Expressing as a Fraction - [Video 136](#)

101. A box contains 20 counters.
Some of the counters are red and the rest are white.
There are 7 white counters in the box.

What fraction of the counters in the box are red?

.....

102. Write 50p as a fraction of £2
Give your answer in its lowest terms.

.....

Fractions of Shapes - [Video 143](#)

103. Write down the fraction of the shape that is shaded.

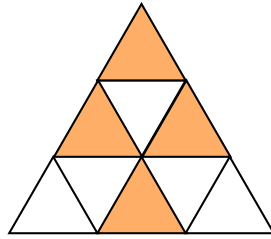

.....

104. Shade in $\frac{3}{4}$ of the grid.

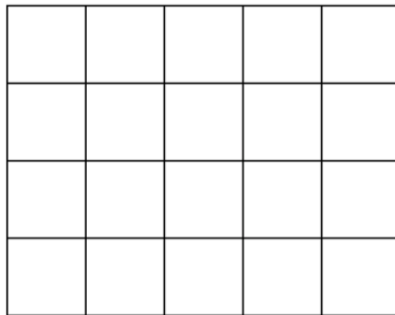

Simplifying Fractions - [Video 146](#)

105. Simplify $\frac{6}{10}$

.....

106. Simplify $\frac{20}{30}$

.....

107. Simplify $\frac{21}{28}$

.....

Equivalent Fractions - [Video 135](#)

108. $\frac{3}{4} = \frac{\square}{8}$

109. $\frac{2}{5} = \frac{6}{\square}$

110. $\frac{4}{8} = \frac{\square}{2}$

Ordering Fractions - [Video 144](#)

111. Arrange these fractions in order, smallest first.

$$\frac{7}{15} \quad \frac{3}{10} \quad \frac{2}{5} \quad \frac{1}{3}$$

Adding & Subtracting Fractions - [Video 133](#)

112. Work out $\frac{5}{8} + \frac{1}{3}$

113. Work out $\frac{7}{15} - \frac{3}{10}$

.....

.....

114. Work out $5\frac{1}{4} + 1\frac{2}{5}$

.....

Multiplying Fractions - [Video 142](#)

115. Work out $\frac{1}{2} \times \frac{2}{3}$

116. Work out $\frac{3}{8} \times 1\frac{2}{5}$

.....

.....

Dividing Fractions - [Video 134](#)

117. Work out $\frac{3}{4} \div \frac{9}{10}$

.....

Reciprocals - [Video 145](#)

118. Write down the reciprocal of 20

.....

119. Write down the reciprocal of $\frac{1}{5}$

.....

120. Write down the reciprocal of $\frac{3}{8}$

.....

121. Write down the reciprocal of $7\frac{1}{2}$

.....

Fractions, Decimals and Percentages - [Videos 129, 130](#)

122. Fill in the missing values

Fraction	Decimal	Percentage
$\frac{1}{2}$	0.5	
	0.25	25%
$\frac{1}{5}$		20%
$\frac{1}{10}$	0.1	

123. Tick **two** numbers that are equivalent to $\frac{3}{5}$

35%

$\frac{30}{50}$

0.35

0.6

Expressing as a Percentage - [Video 237](#)

124. Josie scored 19 out of 20 in a test.

Write Josie's result as a percentage.

.....%

125. There are 29 students in a class.
6 of the students are left handed.

What percentage of the class are left handed?
Give your answer to 1 decimal place.

.....%

Percentages of Amounts (Non-Calculator) - [Video 234](#)

126. Work out 50% of 18

.....

127. Work out 10% of 350

.....

128. Work out 25% of 32

.....

129. Decrease 90 by 30%

.....

130. Work out 175% of 60

.....

Percentages of Amounts (Calculator) - [Video 235](#)

131. Work out 3% of 2800

.....

132. Work out 34% of 700

.....

Percentage Change - [Video 233](#)

133. Eoin bought an antique for €35
He sold the antique for €49

Work out the percentage profit

.....%

134. Last year, a football team sold 800 season ticket
This year, the team sold 745 season tickets

Calculate the percentage decrease.

.....%

Simple Interest - [Video 236a](#)

135. Niamh invests £500 for 2 years at 3% simple interest.
Work out how much interest Niamh earns at the end of the 2 years.

£.....

Multipliers - [Video 239](#)

136. Increase 120 by 10%

.....

137. Decrease 60 by 25%

.....

Compound Interest - [Video 236](#)

138. Fiona leaves £1600 in the bank for three years.
It earns compound interest of 4% each year.

Calculate the total amount Fiona has in the bank at the end of the three years.

£.....

Reverse Percentages - [Video 240](#)

139. The price of a chair is reduced by 20% in a sale.
The sale price of the chair is £20.80

What is the normal price of the chair?

£.....g

140. A limited edition bag of sugar contains 35% more than a standard bag.
The limited edition bag contains 702g of sugar.

How much sugar is in the standard bag?

.....g

Simplifying Ratios - [Video 269](#)

141. Maisie makes 8 chocolate cupcakes and 22 lemon cupcakes.

Write down the ratio of chocolate to lemon cupcakes in its simplest form.

.....

142. Logan has 80p and Sam has £2

Write down the ratio of how much money Logan has to how much money Sam has.
Give your answer in its simplest form.

.....

Ratio: 1:n or n:1 - [Video 271c](#)

There are 180 red pens and 40 black pens in a box.

143. Write down the ratio of red pens to black pens in the box.
Give your answer in the form $n : 1$

.....

Forming Ratio - [Video 271c](#)

In a bag, there are red, yellow and blue sweets.
There are twice as many red sweets as yellow sweets.
There are three times as many blue sweets as red sweets.

144. Write down the ratio of the number of red sweets : yellow sweets : blue sweets

.....

Ratio & Fractions - [Video 269a](#)

The ratio of red to white counters in a bag is 3:5

145. What fraction of the counters are red?

.....

146. What percentage of the counters are white?

.....

147. Mark says that there are 72 counters in the bag.
Could Mark be correct?

.....

Sharing in a Ratio - [Video 270](#)

148. The ratio of adults to children on a flight is 17:3
There are 160 people altogether on the flight.

How many children are on the flight?

.....

Given One Quantity - [Video 271](#)

149. The ratio of the size of angle A to angle B is 4:9
Angle B is 72°

Find the size of angle A.

.....^o

Given Two Ratios - [Video 271a](#)

150. Given that $a : b = 2 : 3$ and $b : c = 5 : 1$

Find $a : b : c$

.....

Ratios and Equations - [Video 271a](#)

151. $y : x = 5 : 1$

Write an equation linking x and y .

.....

152. $x : y = 2 : 5$

Write an equation linking x and y .

.....

153. $y = 3x$

Write the ratio $x : y$

.....

Unitary Method - [Video 255a](#)

154. 28 marbles have a mass of 91g.

What is the mass of 100 marbles?

.....g

Exchange Rates - [Video 214a](#)

155. Orla went to Spain.
She changed £425 into euros (€).

The exchange rate was £1 = €1.16

Change £425 into euros.

€.....

156. On her return to Belfast, Orla changed €80 into pounds (£).

The new exchange rate was £1 = €1.25

Change €80 into pounds.

£.....

Recipes - [Video 256](#)

157. Rebecca is making chilli con carne.
Here is a list of ingredients to serve 6 people.

serves 6

1.2kg mince
420g tomatoes
3 chillies
600g kidney beans

How much of each ingredient does Rebecca need for 4 people?

Mince

Tomatoes

Chillies

Kidney beans

Proportion - [Video 254](#)

158. The number of months, m , to complete a piece of research is found by $m = \frac{400}{n}$

where n is the number of scientists working on the research.

How long should the research take if 8 scientists are working on it?

.....

Direct Proportion - [Video 254](#)

159. y is directly proportional to x

Circle the equation the correct equation.

$y = \frac{k}{x}$ $y = \frac{x}{k}$ $y = kx$

Inverse Proportion - [Video 254](#)

160. y is inversely proportional to x

Circle the equation the correct equation.

$y = \frac{k}{x}$ $y = \frac{x}{k}$ $y = kx$

Proportion Graphs - [Video 254](#)

161. Sketch the graph of y is directly proportional to x .

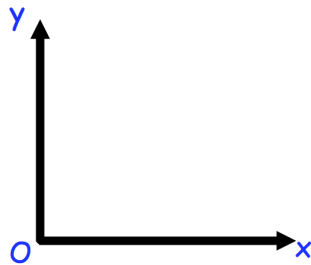

Proportion: Time - [Video 255c](#)

It takes 5 builders, 8 days to build a wall.

162. How long would it take 2 builders?
.....

163. State an assumption that you have made in working out your answer.
.....

Money - [Video 400](#)

164. Emily buys a new TV.

The TV costs £460

She pays a deposit of £190 and then pays 10 equal monthly payments.

How much is each monthly payment?

£.....

Best Buys - [Video 210](#)

165. A shop sells the same type of highlighter in two different packs.

Pack A has 6 highlighters and costs £3.50

Pack B has 9 highlighters and costs £5.30

Which pack is better value for money?

.....

Use of a Calculator - [Video 352](#)

166. Calculate the value of $\frac{5}{0.8^3}$

.....

167. Calculate the value of $\frac{\sqrt{9 \times 0.13}}{9.11 + 2.9}$

.....

Error Intervals - [Video 377](#)

168. Jessica rounds a number, y , to the nearest hundred.
Her result is 2800.

Write down the error interval for y .

Types of Angle - [Video 38](#)

169. Tick the two acute angles and circle the two right angles.

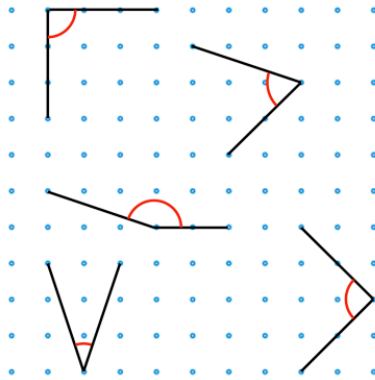

Drawing Angles - [Video 28](#)

170. Draw a 40 degree angle.

Measuring Angles - [Video 31](#)

171. Write down the size of the angle being measured.

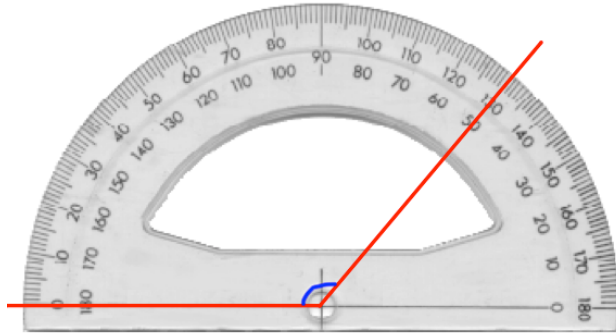

.....°

Angle Facts - [Videos 34, 35, 30, 39](#)

172. Find the size of angle x .

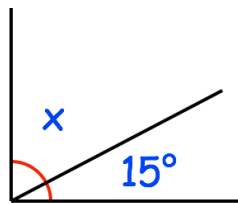

.....°

173. Find the size of angle y .

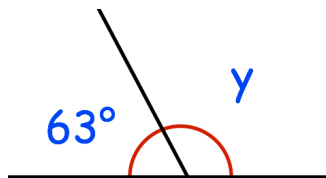

.....°

174. Find the size of angle x .

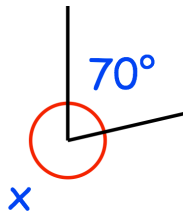

.....^o

175. Find the size of angle y .

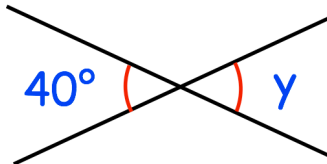

.....^o

Angles in a Triangle - [Video 37](#)

176. Find the size of angle y .

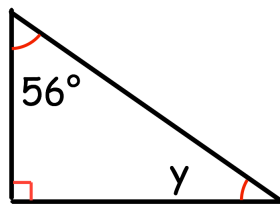

.....^o

Angles in a Quadrilateral - [Video 33](#)

177. Find the size of angle a .

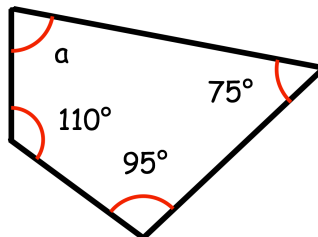

.....^o

Angles (polygons) - [Video 32](#)

178. Find the size of angle x .

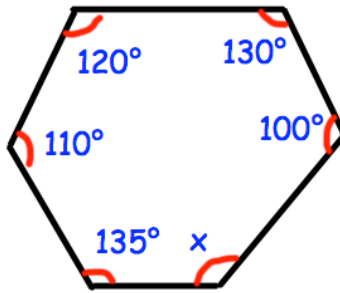

.....^o

179. Work out the sum of the interior angles for 18 sided polygon.

.....^o

180. The sum of the interior angles in a polygon is 3960°
Work out the number of sides the polygon has.

..... sides

181. Calculate the size of each interior angle in a regular polygon with 40 sides.

.....^o

182. Calculate the size of each exterior angle in a regular polygon with 45 sides.

.....^o

Angles in Parallel Lines - [Video 25](#)

183. Find the sizes of angles x and y .

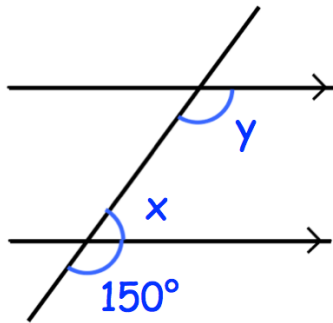

$x = \dots\dots\dots^\circ$ $y = \dots\dots\dots^\circ$

Scales - [Video 283, 284](#)

184. A map has a scale of 1cm : 10 km
On the map, the distance between two towns is 2.3cm.

What is the actual distance between the two towns?

.....

Maps - [Video 283](#)

185. A school is 300m West of the hotel.
Show this on the map below.

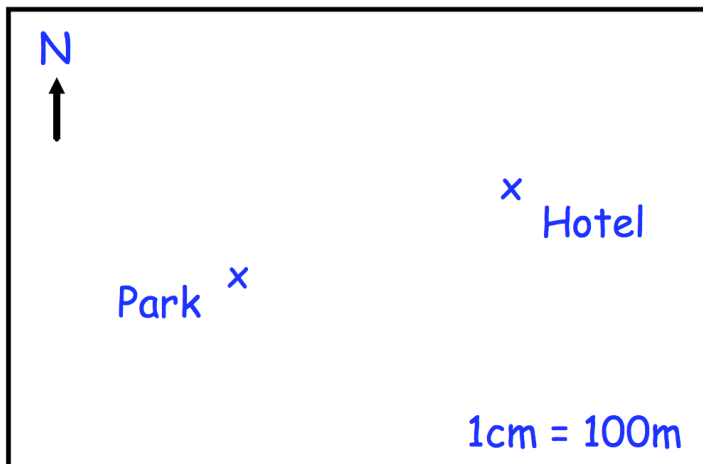

Compass Directions - [Video 27b](#)

186. Tom is facing East and turns 90° clockwise.

Which direction is Tom now facing?

.....

187. Town A is North West of Town B.

Town B is of Town A.

Bearings - [Video 26](#)

188. Write down the three figure bearing of Newry from Armagh



x Newry

.....°

189. Write down the three figure bearing of Omagh from Cookstown



.....^o

Back Bearings - [Video 27a](#)

190. The bearing of town A from town B is 140°
What is the bearing of town B from town A?

.....^o

Perimeter on a Grid - [Video 242](#)

191. The shape below is drawn on a centimetre grid.
Find the perimeter of the shape.

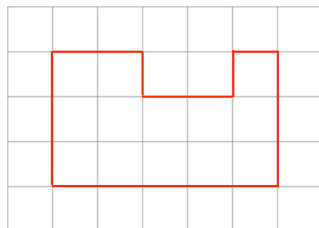

.....cm

Perimeter - [Video 241](#)

192. Find the perimeter of this rectangle

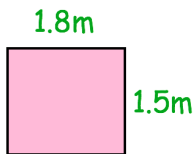

.....m

Area on a Grid - [Video 43](#)

193. The shape below is drawn on a centimetre grid.
Find the area of the shape.

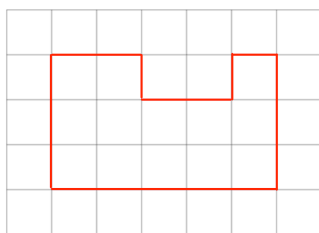

.....cm²

Area of a Rectangle - [Video 45](#)

194. Find the area of this rectangle



.....cm²

Area of a Triangle - [Video 49](#)

195. Find the area of this triangle

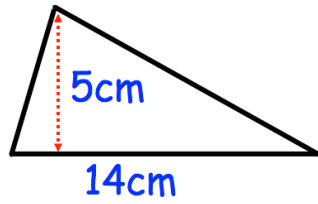

.....cm²

Area of a Parallelogram - [Video 44](#)

196. Calculate the area of the parallelogram

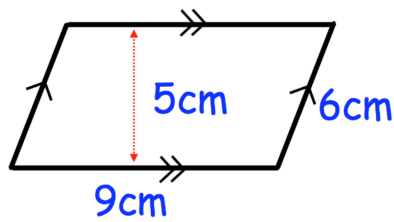

.....cm²

Area of a Trapezium - [Video 48](#)

197. Calculate the area of the trapezium

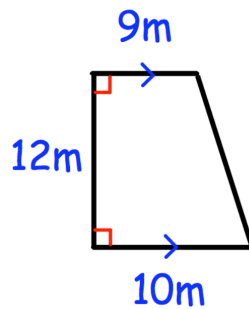

.....m²

Area of Compound Shapes - [Video 41](#)

198. Calculate the area of this compound shape.

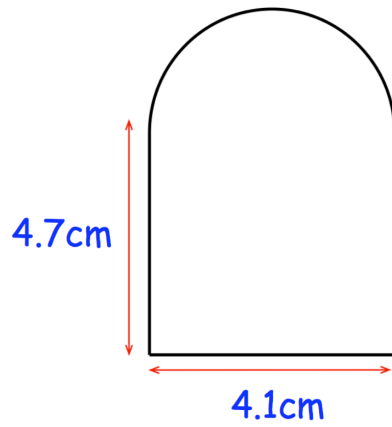

.....cm²

Units - [Videos 349a](#), [349b](#), [349c](#)

199. Write 4 metres in centimetres

.....cm

200. Write 1900 centimetres in metres

.....m

201. Write 16 centimetres in millimetres

.....mm

202. Write 800 grams in kilograms

.....kg

203. Write 1.2 kilograms in grams

.....g

204. Write 7.1 tonnes in kilograms

.....kg

205. Write 2.5 litres in millilitres

.....ml

206. Write 330 millilitres in litres

.....L

Sensible Estimates - [Video 285](#)

207. Estimate the height of a classroom door.
Circle the suitable answer.

2mm

2cm

2m

2km

208. Estimate the weight of a field mouse

19kg

1.9 tonnes

19 grams

1.9kg

Imperial Units - [Videos 349a, 349b, 349c](#)

209. Given that 5 miles = 8 kilometres, convert 25 miles in kilometres

.....km

Line Symmetry - [Video 316](#)

210. Draw all the lines of symmetry on the shape below.

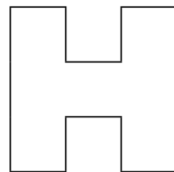

Rotational Symmetry - [Video 317](#)

211. Write down the order of rotational symmetry of the sign below.



.....

Constructions - [Videos 78, 72, 79](#)

212. Use ruler and compasses to construct the perpendicular bisector of AB .
You must show clearly all your construction arcs.

A .

. B

Loci - [Videos 75 to 77](#)

213. A farm is closer to Newtown than to Redville.
It is less 6 miles away from the Airport.

Shade the region on the map where the farm could be.

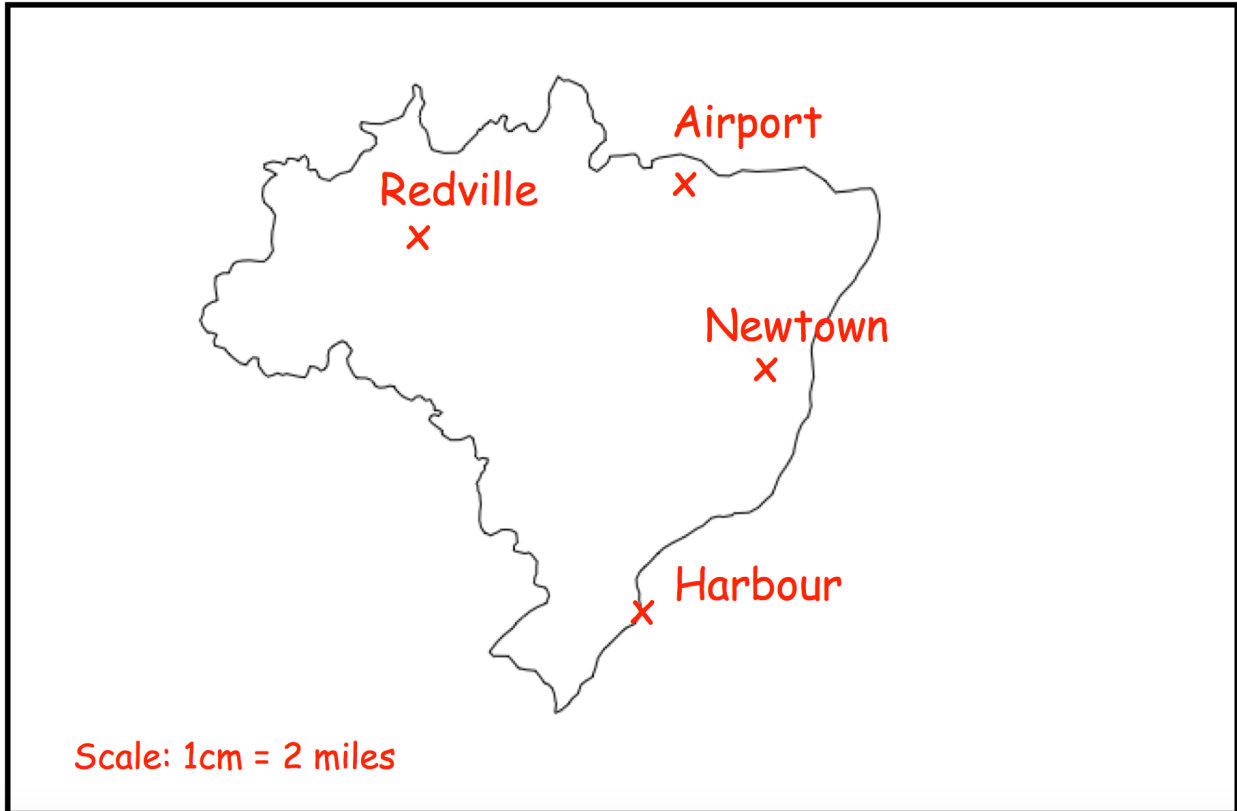

2D Shapes - [Video 1](#)

214. Match each shape to the correct name



Pentagon



Octagon

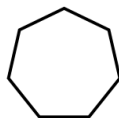

Heptagon

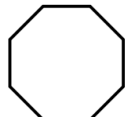

Triangle

Types of Triangle - [Video 327](#)

215. Match each triangle to the correct name

Triangle

Name

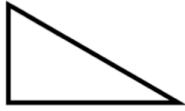

Isosceles

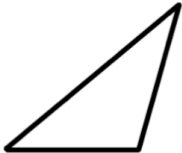

Right angled

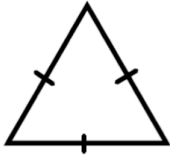

Equilateral



Scalene

Quadrilaterals - [Video 2](#)

216. Here is a quadrilateral.
It has two pairs of parallel sides.

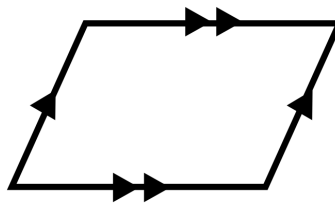

Write down the name of this quadrilateral.

.....

3D Shapes - [Video 3](#)

217. Match each shape to the correct name

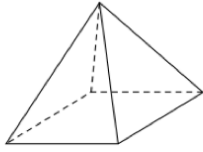

Sphere

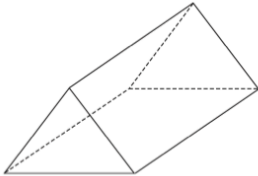

Triangular Prism

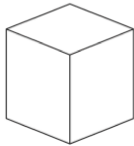

Square-based Pyramid

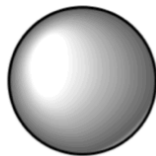

Cube

Edges, Faces, Vertices - [Video 5](#)

218. Here is a triangular prism.

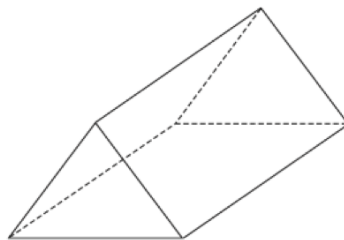

How many faces does it have?

.....

How many edges does it have?

.....

How many vertices does it have?

.....

Nets - [Video 4](#)

219. Match each 3D shape to the correct net.

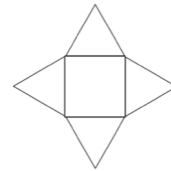
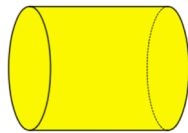
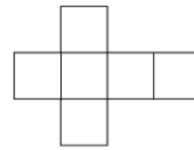
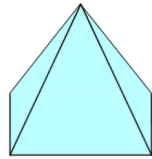
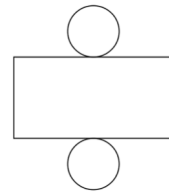
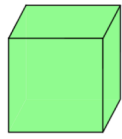

Parallel and Perpendicular Lines - [Videos 231, 232](#)

220. Draw a pair of parallel lines.

221. Draw a pair of perpendicular lines.

Views and Elevations - [Video 354](#)

222. Shown below is a solid shape made from 6 centimetre cubes.

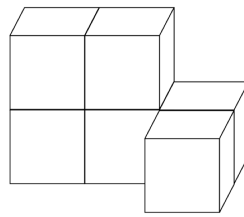

Front

On the centimetre square grid, draw the front elevation.

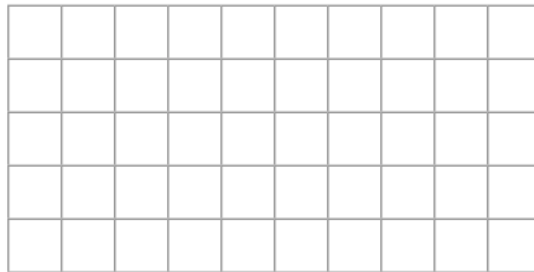

On the centimetre square grid, draw the plan view.

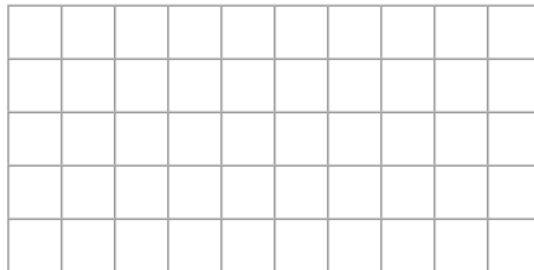

Time Calculations - [Video 322](#)

223. A television programme lasted 85 minutes.
The programme finished at 17:00

What time did the television programme begin?

.....

Timetables - [Video 320](#)

Ballymena	15 12	16 12	17 12
Antrim	15 34	-----	17 34
Templepatrick	15 50	-----	17 50
Belfast	16 10	17 00	18 10

224. Dylan arrived in Templepatrick at 17:50
What time did he catch the bus in Antrim?

.....

225. Orla plans to catch the 16:12 from Ballymena to Belfast.
How long should her journey last?

.....

Distance Charts - [Video 318](#)

226. The distance chart below shows distances, in miles, between some locations.

Belfast				
56	Coleraine			
38	94	Newry		
23	47	60	Larne	
55	19	94	48	Ballycastle

Isla drives from Belfast to Ballycastle and then to Larne.

How far does Isla drive?

.....miles

Speed, Distance, Time - [Video 299](#)

227. A car travels 300 miles in 5 hours.

Work out the average speed of the car.

.....mph

228. Richard runs at a speed of 8m/s for 25 seconds.

How far does Richard run?

.....m

229. Paige drives 90 miles at a speed of 60mph.
How long does the journey take?

.....

Distance-Time Graphs - [Video 171](#)

A train travels from Milton to Redville, stops for 30 minutes and then travels to Leek.

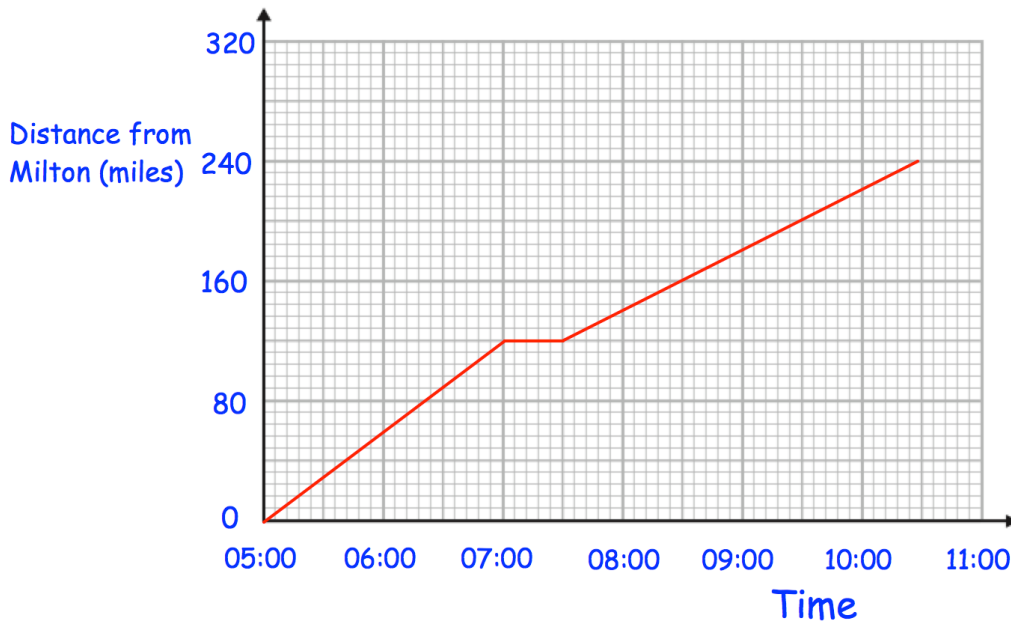

230. How far is Redville from Milton?

.....miles

231. How long did it take the train to travel from Redville to Leek?

.....

232. Work out the average speed of the train for the journey from Milton to Redville

.....mph

Density - [Video 384](#)

233. A piece of aluminium has a mass of 575.4g and a volume of 210cm³

Calculate the density of the aluminium

.....g/cm³

234. A statue has a volume of 120cm³ and is made from zinc with a density of 7.14g/cm³

Calculate the mass of the statue

.....g

Pressure - [Video 385](#)

235. A cube with side length 8cm is placed on a table.
The cube exerts a force of 400N on the table.

Work out the pressure on the table in Newtons/cm²

.....N/cm²

Translations - [Video 325](#)

236.

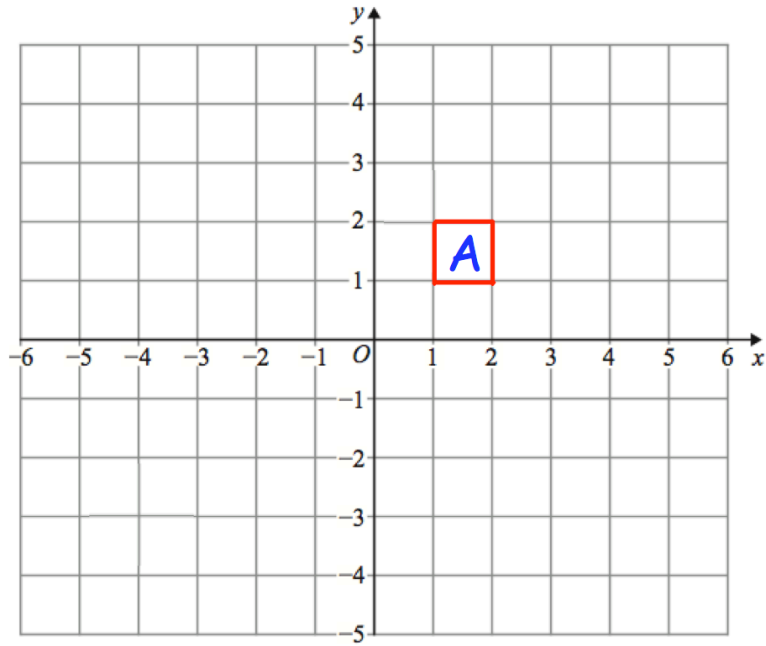

Translate A by $\begin{pmatrix} 2 \\ -3 \end{pmatrix}$

Rotations - [Video 275](#)

237.

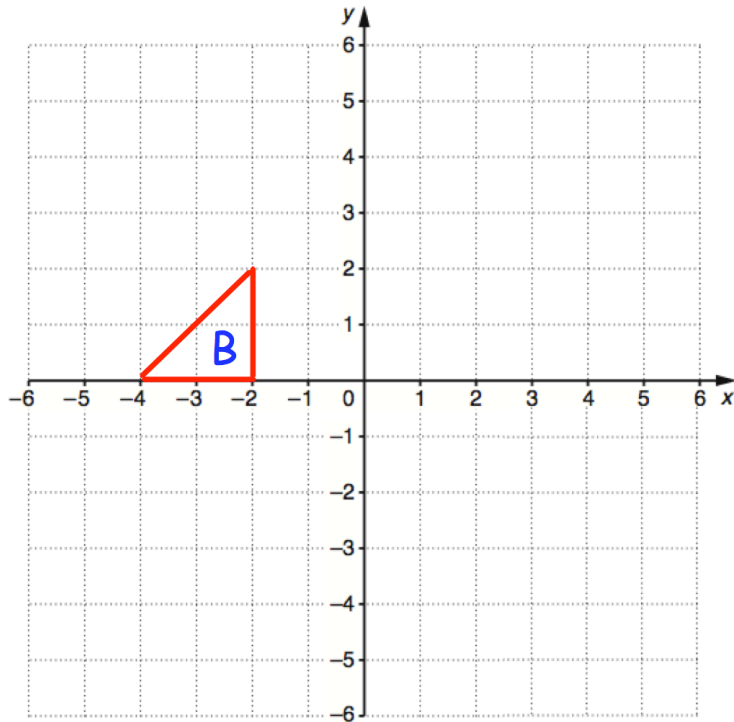

rotate 90° clockwise about $(-1, -2)$

Reflections - [Video 272](#)

238.

Reflect shape F in the line $y = 3$

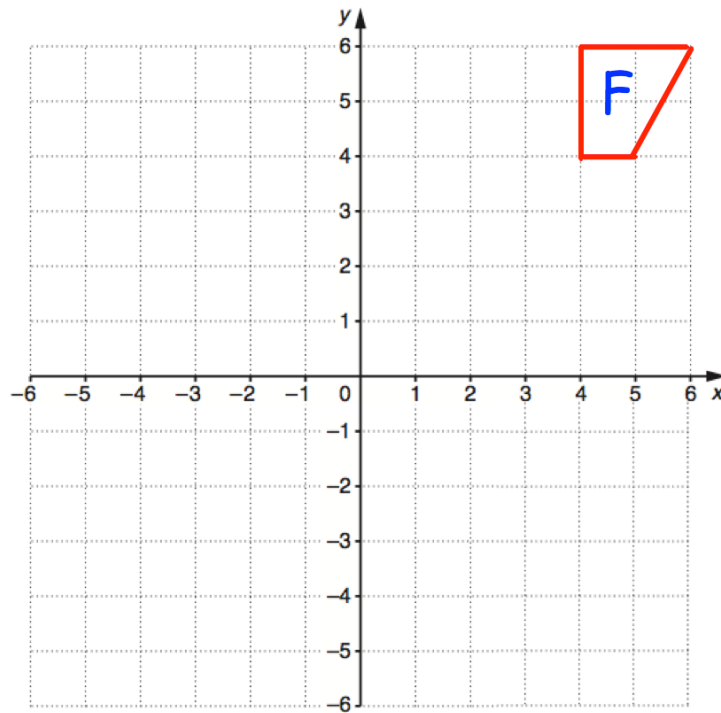

Enlargements - [Videos 104, 104a](#)

239.

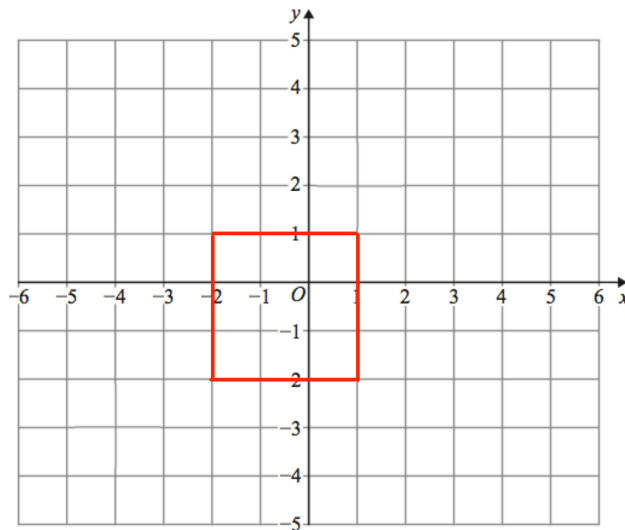

Enlarge by scale factor 2 using $(0, -1)$ as the centre of enlargement

Parts of a Circle - [Video 61](#)

240.

Label	Diagram
Circle and radius	
Circle and segment	
Circle and arc	
Circle and diameter	
Circle and tangent	
Circle and chord	

Circumference - [Video 60](#)

241. Calculate the circumference of this circle.
Give your answer to 1 decimal place.

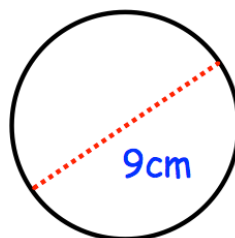

.....cm

Perimeter of a Semi-Circle - [Video 243](#)

242. Calculate the perimeter of this semi-circle

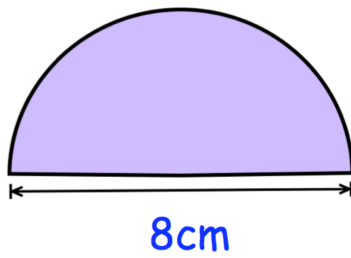

.....cm

Arc Length - [Video 58](#)

243. Find the perimeter of this sector.
Give your answer to 1 decimal place.

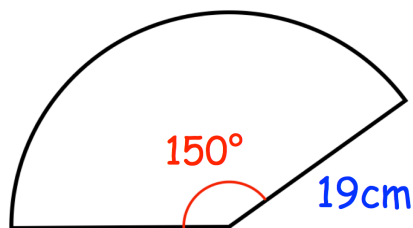

.....cm

Area of a Circle - [Video 59](#)

244. Calculate the area of this circle.
Give your answer to 1 decimal place.

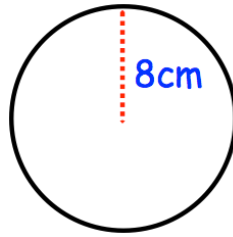

.....cm²

Area of a Semi-Circle - [Video 47](#)

245. Calculate the area of this semi-circle

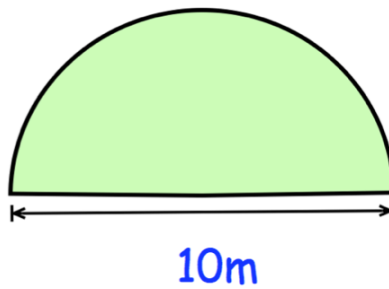

.....m²

Area of a Sector - [Video 46](#)

246. Find the area of this sector.
Give your answer to 1 decimal place.

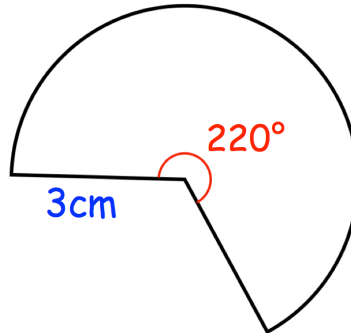

.....cm²

Pythagoras - [Video 257](#)

247. Find x.
Give your answer to 2 decimal places.

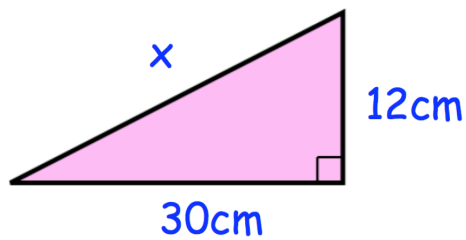

.....cm

248. Find x .
Give your answer to 2 decimal places.

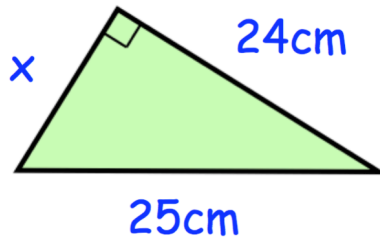

.....cm

Trigonometry - [Videos 329, 330, 331](#)

249. Find x

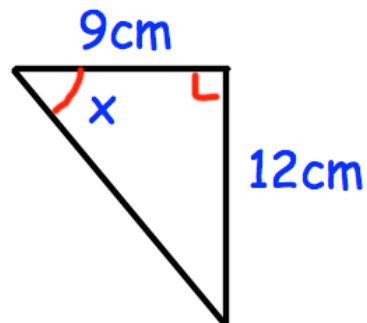

.....°

250. Find x

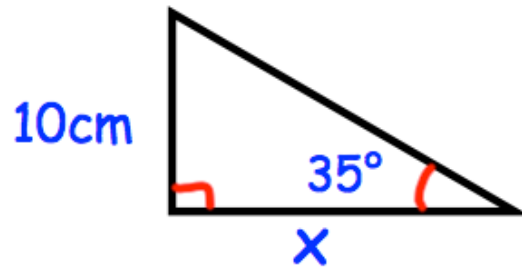

.....cm

251. Find x

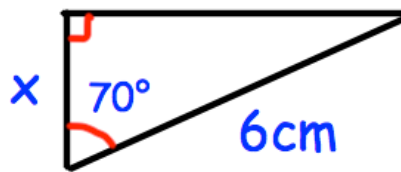

.....cm

Exact Trig Values - [Videos 329, 330, 331](#)

252. Write down the value of $\cos 90^\circ$

.....

Similar Shapes - [Video 292](#)

253. Shown below are two mathematically similar rectangles

Not drawn accurately

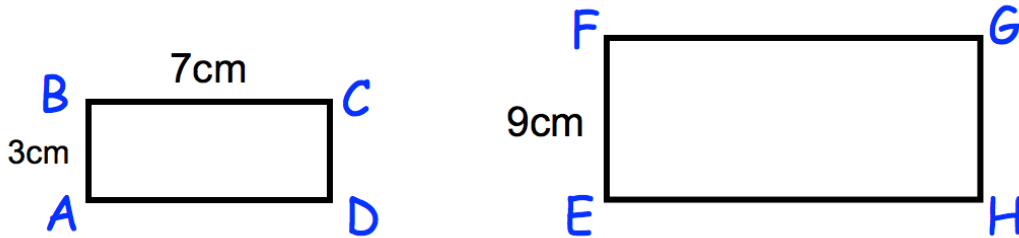

Find the length of FG

.....cm

Congruent Shapes - [Video 66](#)

254.

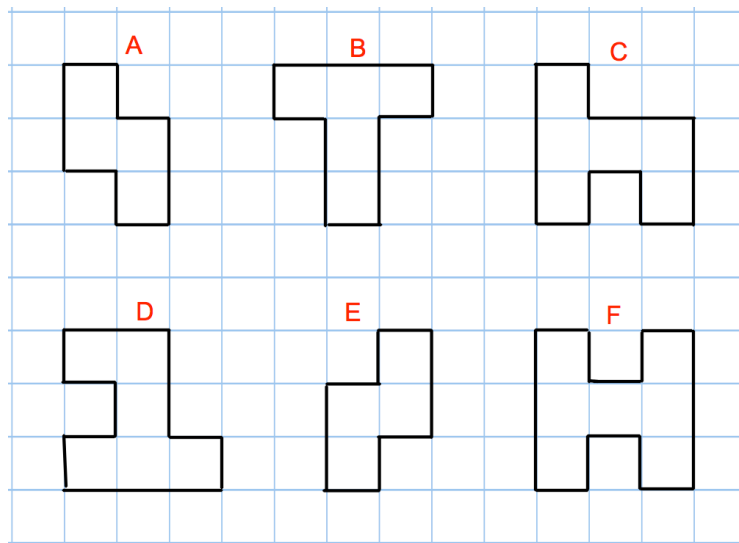

Which shape is congruent to shape E?

.....

Congruent Triangles - [Video 67](#)

255. Shown below are six triangles that are not drawn accurately.

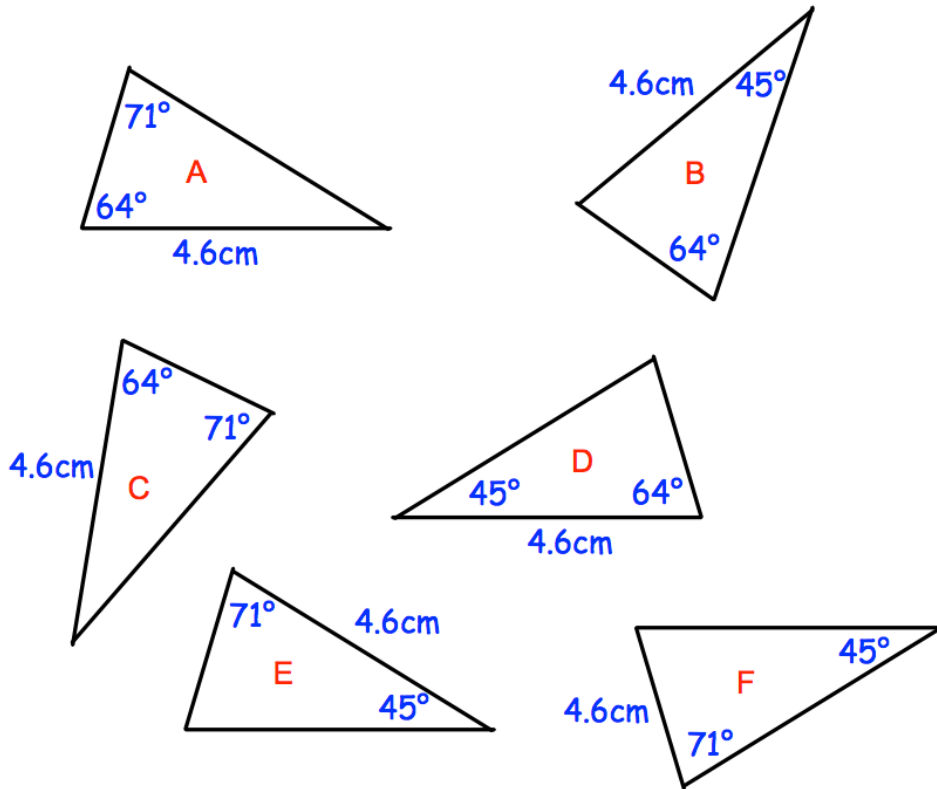

Which two triangles are congruent to triangle A?

..... and

Volume of a Cuboid - [Video 355](#)

256. Work out the volume of this cuboid.

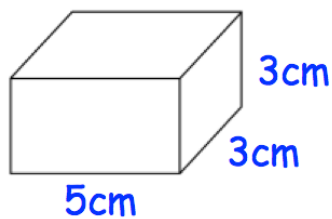

..... cm^3

Volume of a Prism - [Video 356](#)

257. Calculate the volume of the triangular prism.

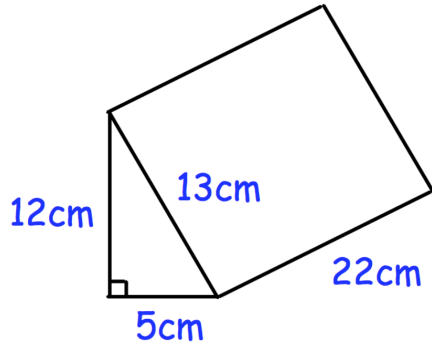

.....cm³

Volume of a Cylinder - [Video 357](#)

258. Calculate the volume of the cylinder.

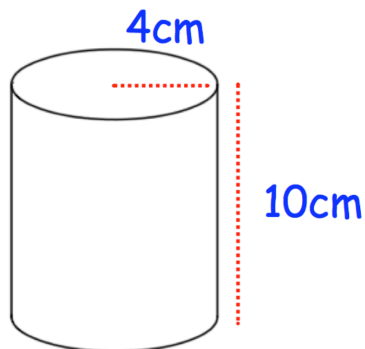

.....cm³

Volume of a Cone - [Video 359](#)

259. Calculate the volume of the cone.
Give your answer to 1 decimal place.

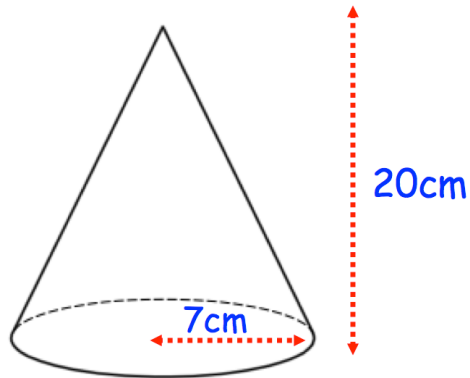

.....cm³

Volume of a Cone - [Video 359](#)

260. A rectangular-based pyramid is shown below.

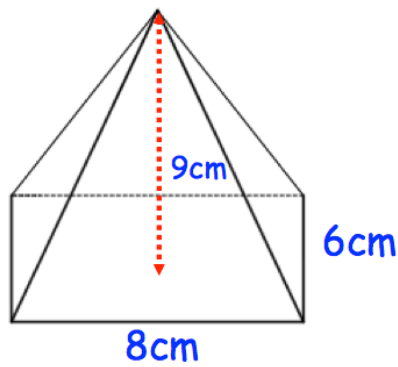

Calculate the volume of the pyramid.

.....cm³

Volume of a Sphere - [Video 361](#)

261. Calculate the volume of the sphere.
Give your answer to 1 decimal place.

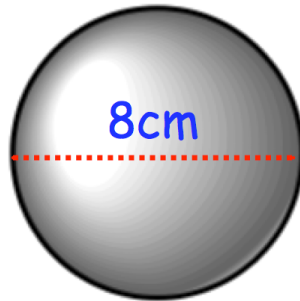

.....cm³

Surface Area - [Video 310](#)

262. Work out the surface area of this cuboid.

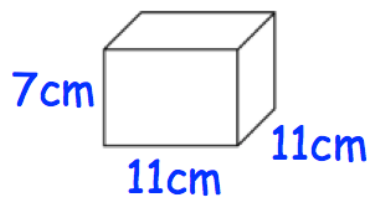

.....cm²

Surface Area of a Sphere - [Video 313](#)

263. Calculate the surface area of the sphere.
Give your answer to 1 decimal place.

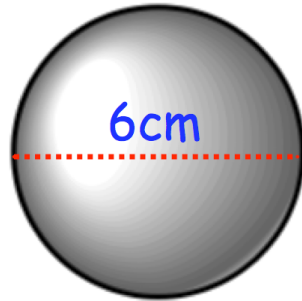

.....cm²

Surface Area of a Cone - [Video 314](#)

264. Calculate the surface area of the cone.
Give your answer to 1 decimal place.

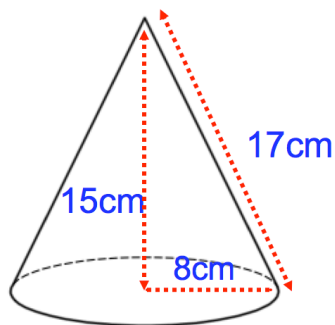

.....cm²

Converting Units for Area/Volume - [Videos 350, 351](#)

265. Write 7m^2 in cm^2

..... cm^2

266. Write 19000000cm^3 in m^3

..... m^3

Column Vectors - [Video 353a](#)

267. $\mathbf{a} = \begin{pmatrix} 2 \\ 0 \end{pmatrix}$ and $\mathbf{b} = \begin{pmatrix} 1 \\ 5 \end{pmatrix}$

Work out $4\mathbf{a} + 2\mathbf{b}$

.....

Vectors - [Video 353](#)

268.

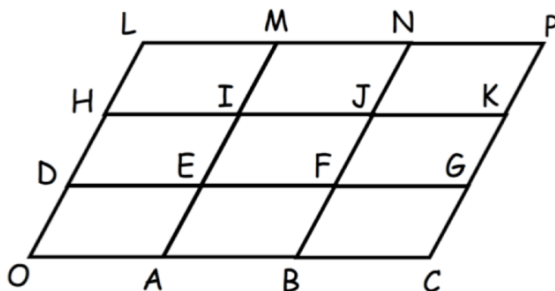

$\vec{OA} = \mathbf{a}$ $\vec{OB} = \mathbf{b}$

Write \vec{OI} in terms of \mathbf{a} and \mathbf{b}

.....

Writing Expressions - [Video 16](#)

Carl is x years old.

Darragh is three times older than Carl.

Emma is four years younger than Darragh.

Fiona is half Carl's age.

269. Write an expression for Darragh's age.

.....

270. Write an expression for Emma's age.

.....

271. Write an expression for Fiona's age.

.....

Collecting Like Terms - [Video 9](#)

272. Simplify $a + a + a + a - a$

.....

273. Simplify $6x + y - 5x - 5y$

.....

Multiplying Terms - [Video 18](#)

274. Simplify $6 \times w$

.....

275. Simplify $7 \times 3y$

.....

Laws of Indices - [Video 174](#)

276. Simplify $w^8 \times w^4$

.....

277. Simplify $w^{10} \div w^4$

.....

278. Simplify $(w^4)^3$

.....

Expanding Brackets - [Video 13](#)

279. Expand $4(2w - 3)$

.....

280. Multiply out and simplify $2(x + 3) + 4(x - 1)$

281. Expand $y(2y - 3)$

.....

.....

Expanding 2 Brackets - [Video 14](#)

282. Expand and simplify $(x + 5)(x + 6)$

283. Expand and simplify $(x - 8)(x + 6)$

.....

.....

284. Expand and simplify $(x - 12)(x - 3)$

.....

285. Expand and simplify $(5x + 4)(x - 2)$

.....

Factorising - [Video 117](#)

286. Factorise $6x + 8$

.....

287. Factorise $15y - 20$

.....

288. Factorise $4x^3 + 5x$

.....

Factorising Quadratics - [Video 118](#)

289. Factorise $x^2 + 6x + 9$

290. Factorise $x^2 + 12x + 20$

.....

291. Factorise $x^2 + 3x - 10$

.....

292. Factorise $x^2 - 6x - 55$

.....

293. Factorise $x^2 - 12x + 32$

.....

.....

Solving Quadratics - [Video 266](#)

294. Solve $x^2 + 7x + 10 = 0$

.....

295. Solve $x^2 - 2x - 8 = 0$

.....

Difference between 2 Squares - [Video 120](#)

296. Factorise $x^2 - 4$

.....

297. Factorise $81 - x^2$

.....

Substitution - [Video 20](#)

298. Given that $w = 3$ and $y = 9$

find the value of $7w - 2y$

.....

299. x is an odd number
 y is an even number

State if the following are odd or even

$x + y$

.....

xy

.....

Solving Equations - [Video 110](#)

300. Solve $y + 11 = 15$

$y =$

301. Solve $\frac{c}{4} = 8$

c =

302. Solve $6x = 72$

x =

303. Solve $w - 2 = 7$

w =

304. Solve $7y - 4 = 38$

y =

305. Solve $8 + 10y = 58$

y =

Letters Both Sides - [Video 113](#)

306. Solve $7x + 2 = 4x + 29$

$x = \dots\dots\dots$

Forming Equations - [Videos 114, 115](#)

307. Both rectangles have the same perimeter.

Find the value of x .

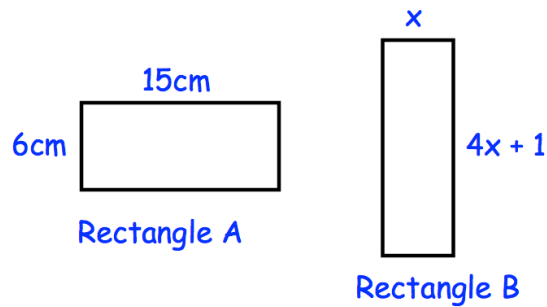

$\dots\dots\dots$

Solving Inequalities - [Video 178](#)

308. Solve $4x < 32$

.....

309. Solve $5x + 1 > 91$

.....

310. Solve $7x - 5 \leq 3x + 11$

.....

Inequalities (number line) - [Video 177](#)

311.

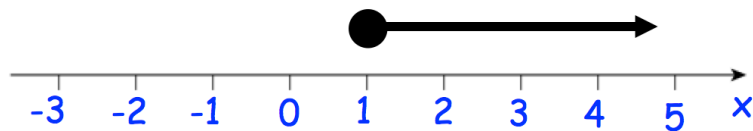

Write down the inequality shown above.

.....

312. Solve the inequality $2x - 1 < 5$ and represent the answer on the number line below.

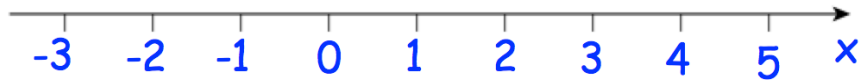

313. List all the integers that satisfy the inequality $4 < 3n < 15$

.....

Changing the Subject - [Video 7](#)

314. Make y the subject of $w = y - a$

$y =$

315. Make x the subject of $m = 2x - y$

$x =$

Equations/Identities - [Video 367a](#)

316. Circle the identity

$4x + 9$

$5x < 4$

$x + x \equiv 2x$

$8x - 3 = 77$

Function Machines - [Video 386](#)

317. Below is a number machine.

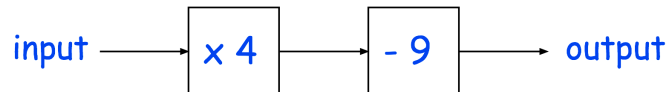

(a) Work out the output when the input is 6

.....

(b) Work out the input when the output is 35

.....

Coordinates - [Video 84](#)

318. The vertices of a quadrilateral have these coordinates.

(3, -2)

(1, -2)

(3, 1)

(-1, 1)

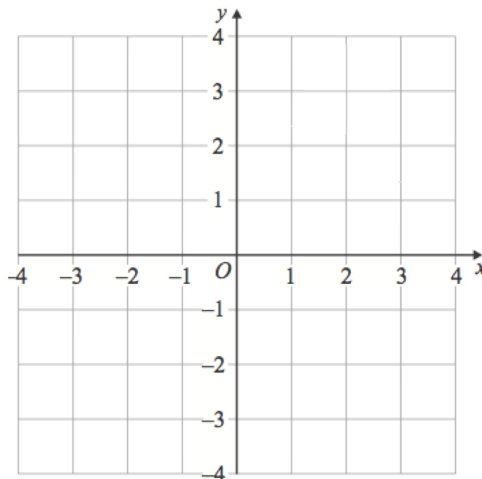

Complete the quadrilateral

Drawing Linear Graphs - [Video 186](#)

319. (a) Complete the table of values for $y = 2x + 4$.

x	-1	0	1	2	3
y		4			10

(b) On the grid, draw the graph of $y = 2x + 4$ for values of x from -1 to 3 .

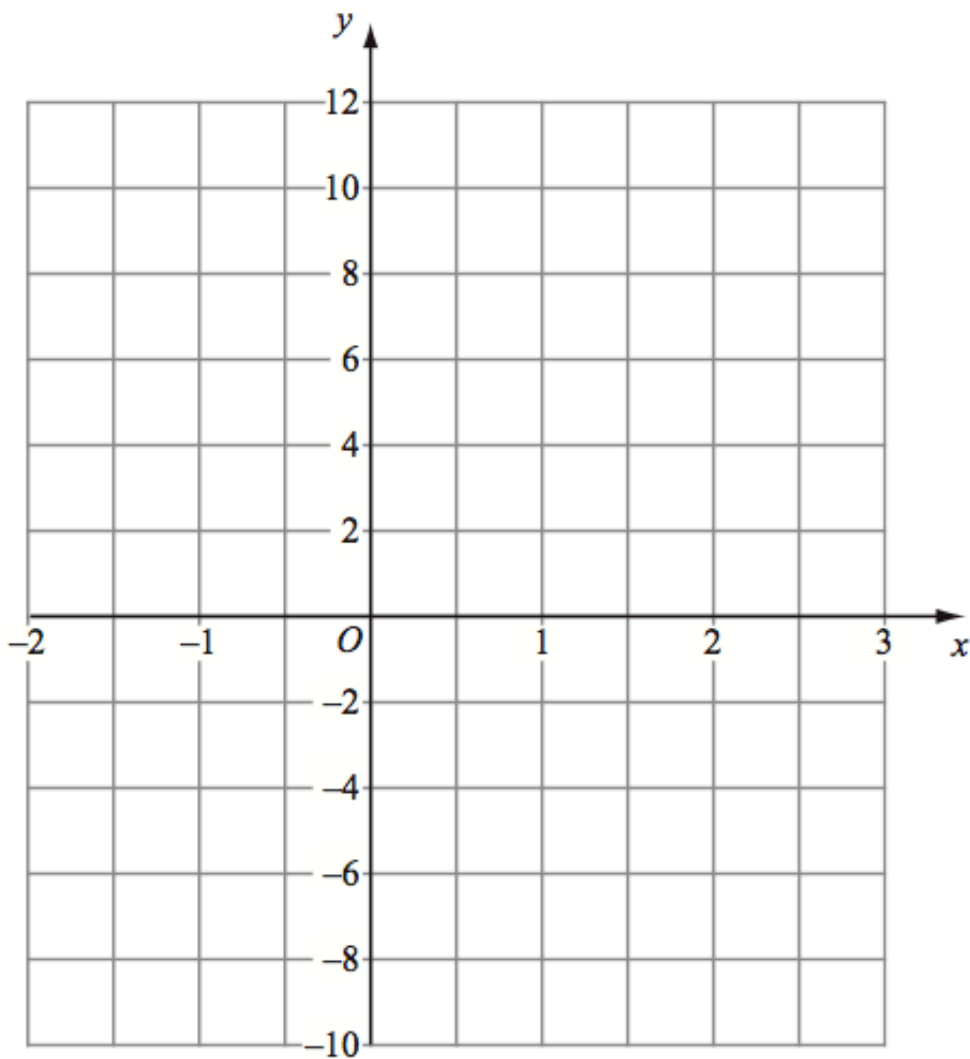

Midpoint of a Line - [Video 198](#)

320. $A(3, -2)$ and $B(7, 10)$

Find the coordinates of the midpoint of AB

Length of a Line - [Video 263](#)

321. Shown below are the points $A(1, 4)$ and $B(7, 15)$

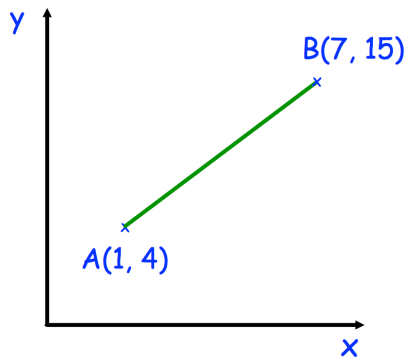

Calculate the length of the line joining A and B .

Graphical Solutions - [Video 297](#)

322. The straight line $y = -2x + 4$ has been drawn on the grid.

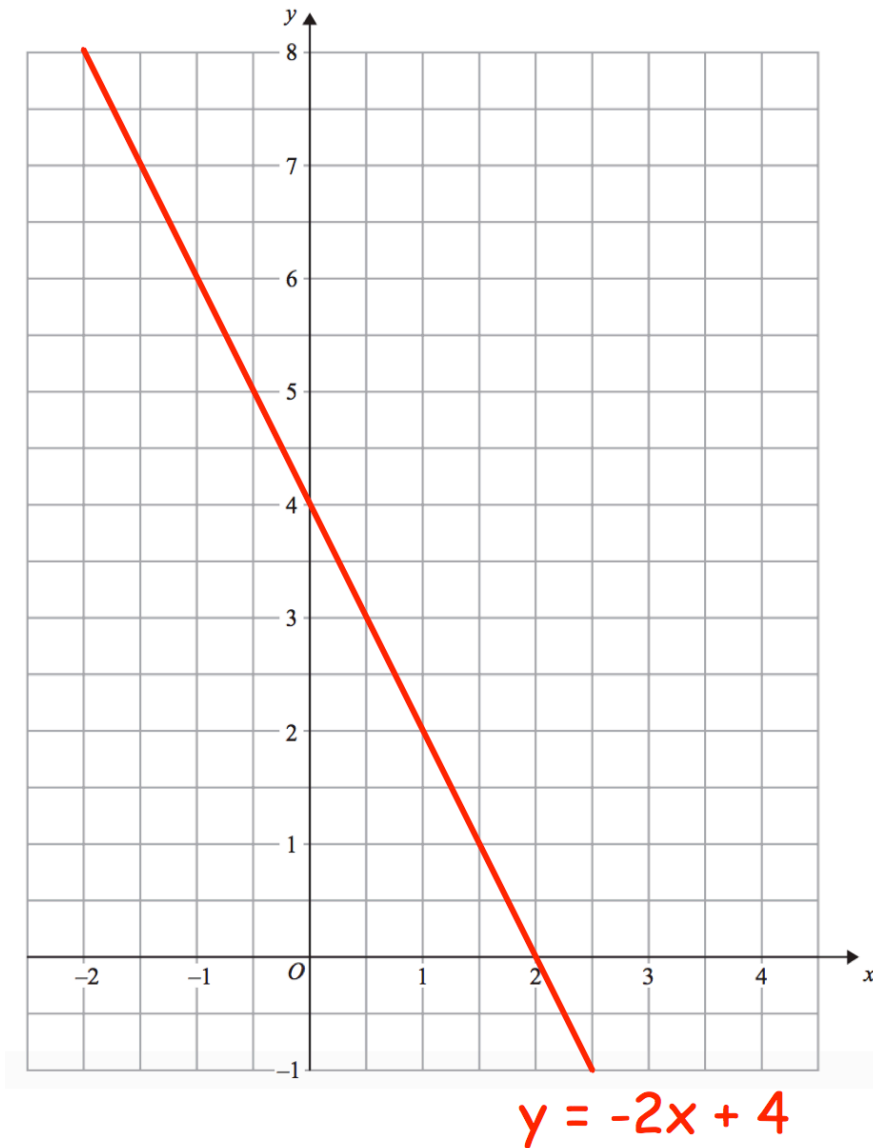

By drawing a suitable line, solve the simultaneous equations

$$y = -2x + 4$$

$$y = x + 1$$

$x = \dots\dots\dots$ $y = \dots\dots\dots$

Gradient - [Video 189](#)

323. Find the gradient of the line below

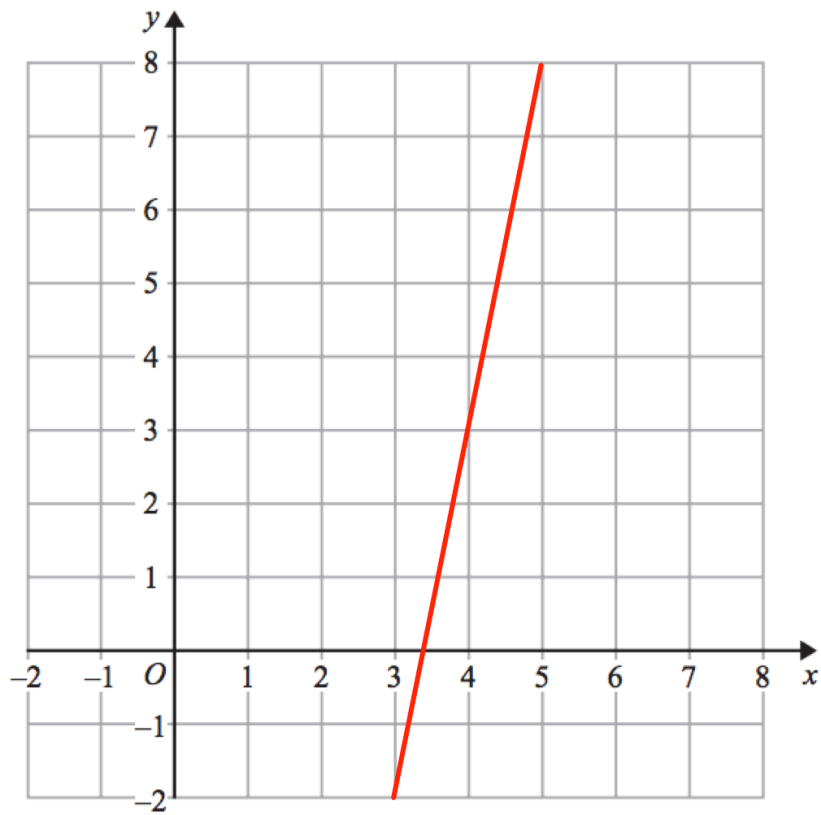

.....

Equation of a Line - [Videos 186 to 195](#)

324. A straight line has equation $y = 5x - 2$

(a) What is the gradient of the line?

.....

(b) Write down the coordinates of the y-intercept

.....

325. Find the equation of the line below

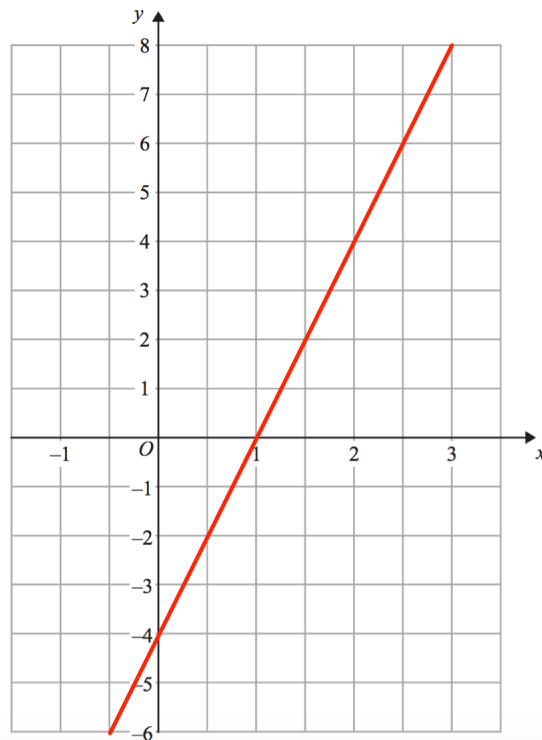

.....

326. A straight line has a gradient of -2 and passes through the point $(1, 10)$.

Write down the equation of the line.

.....

327. Find the equation of the straight line that passes through the points $(0, 3)$ and $(4, 11)$

.....

328. Find the equation of the straight line that passes through the points $(-8, -10)$ and $(0, 14)$

.....

Parallel Lines - [Video 196](#)

329. Write down an equation of a line parallel to $y = 6x + 5$

.....

330. Write down the equation of the line parallel to $y = 3x + 1$ that passes through the point (0, 2)

.....

Real Life Graphs - [Video 171a](#)

331. The graph below shows the depth of water in a container.

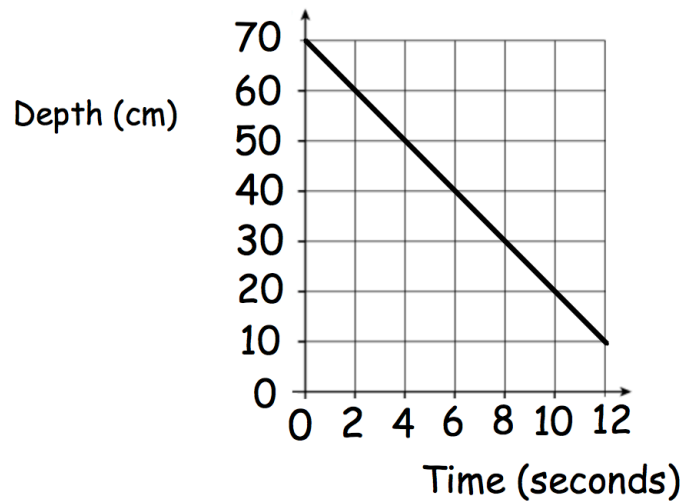

Calculate the gradient of the line

.....

What does the gradient of the line represent?

.....

.....

Conversion Graphs - [Videos 151, 152](#)

332. Complete the table below

Pounds	0	1	10	50
Rupees	0	90		

Draw a conversion graph for converting between pounds and rupees.

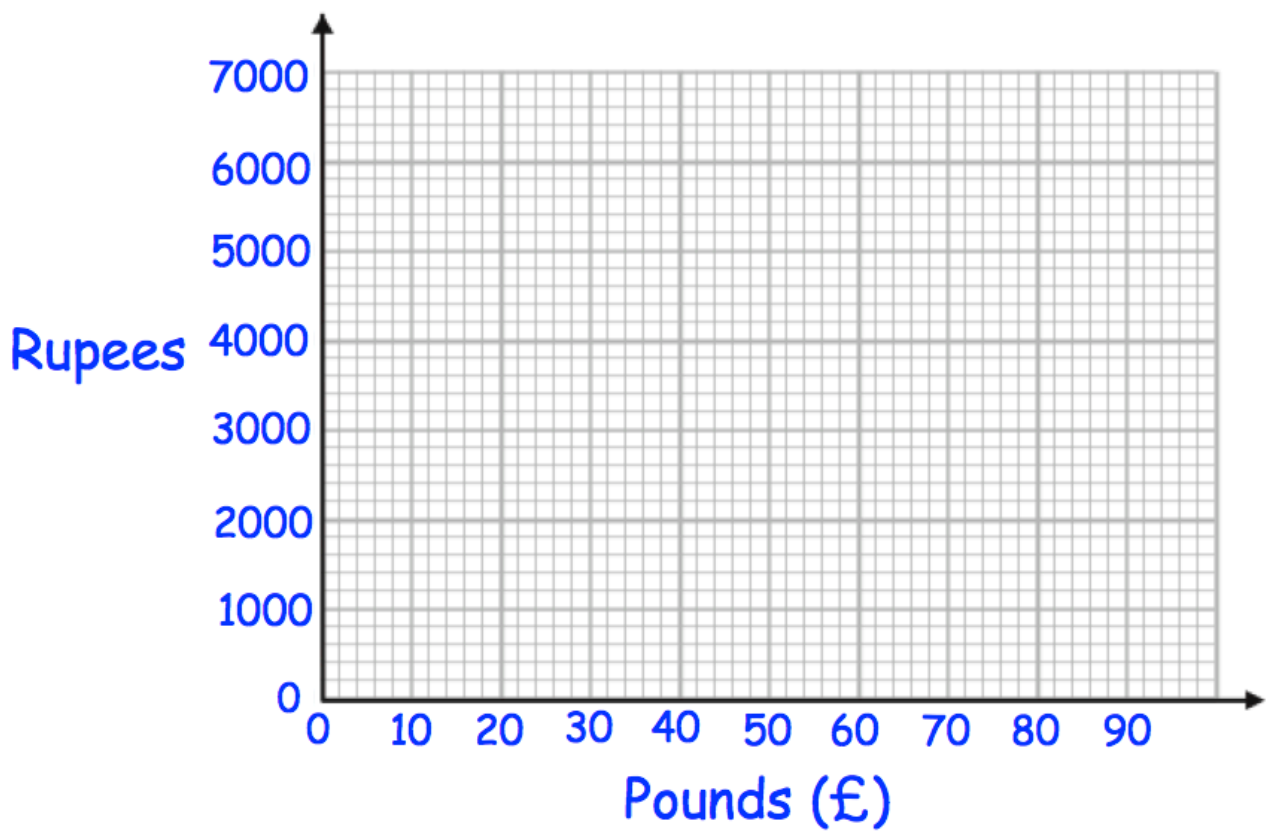

Quadratic Graphs - [Video 264](#)

333. Complete the table of values for $y = x^2 - 2x$

x	-2	-1	0	1	2	3
y		3			0	

334. Draw the graph of $y = x^2 - 2x$

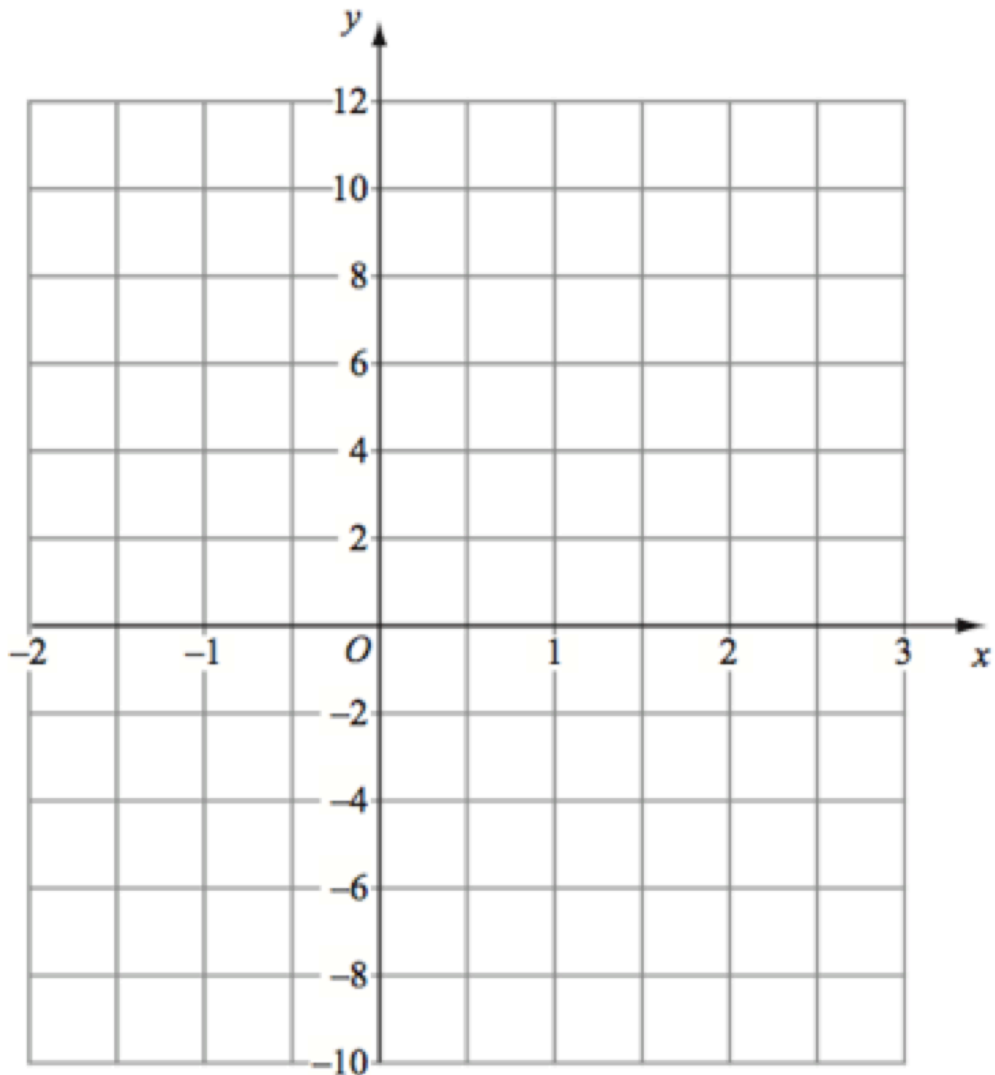

Solving Quadratics Graphically - [Video 267c](#)

335. Use the graph from Question 323 to estimate the values of x when $y = 2$

$x = \dots\dots\dots$ and $x = \dots\dots\dots$

Reciprocal Graphs - [Video 346](#)

336. Complete the table of values for $y = \frac{5}{x}$

x	0.5	1	2	4	8	10
y						

337. On the grid, draw the graph of $y = \frac{5}{x}$ for $0.5 \leq x \leq 10$

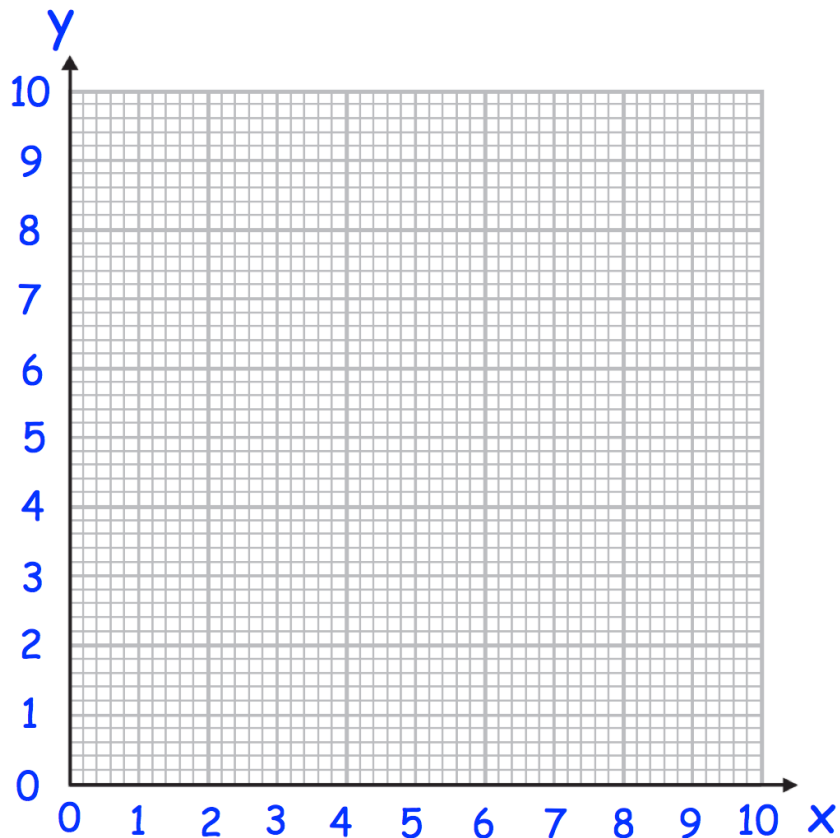

Cubic Graphs - [Video 344](#)

338. Complete the table of values for $y = x^3 - 1$

x	-2	-1	0	1	2
y					

339. On the grid, draw the graph of $y = x^3 - 1$ for $-1 \leq x \leq 2$

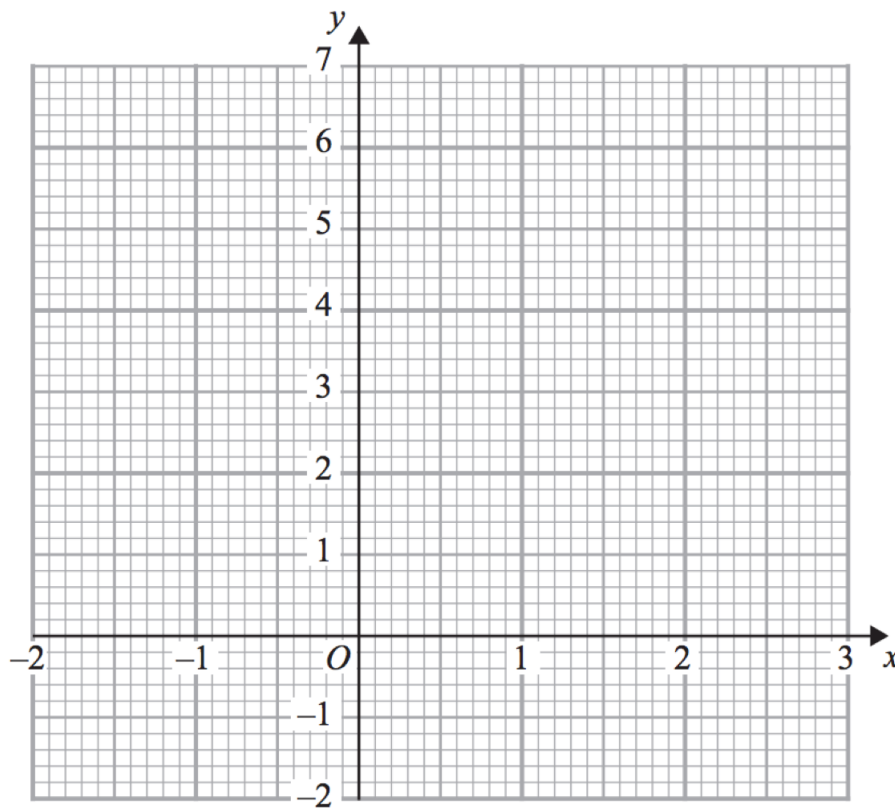

Sequences - [Videos 286, 287](#)

340. Find the next two terms in the sequence 19, 23, 27, 31, ... , ...

..... and

341. Find the next two terms in the sequence 4, 9, 16, 25, ... , ...

..... and

342. Find the next two terms in the sequence 1, 8, 27, 64, ... , ...

..... and

343. Find the next two terms in the sequence 1, 3, 6, 10, ... , ...

..... and

Triangular Numbers - [Video 229](#)

344. List the first 6 triangular numbers

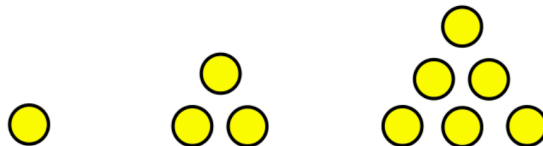

Generating Sequences - [Video 290a](#)

345. Ciara forms a sequence by using the rule:

"Find the next term by adding the previous two terms."

The first three terms of Ciara's sequence are 2, 5 and 7.
Find the next two terms of Ciara's sequence.

..... and

Patterns - [Video 290](#)

These patterns are made of sticks.

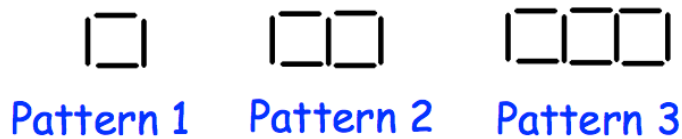

346. Draw Pattern 4

347. How many sticks will there be in Pattern 6?

.....

Fibonacci - [Video 287a](#)

348. Here are the first five terms of a Fibonacci sequence.

2 5 7 12 19

Write down the next two terms of the sequence.

..... and

nth Term - [Video 288](#)

349. Find the nth term of 9, 20, 31, 42

.....

350. Find the nth term of 50, 48, 46, 44

.....

351. Find the nth term and the 100th term of 7, 10, 13, 16

nth term =

100th term =

Arithmetic/Geometric Progressions - [Video 375](#)

352. Circle the geometric progression.

11, 9, 7, 5 ...

1, 4, 9, 16 ...

11, 21, 31, 41 ...

1, 4, 16, 64 ...

Simultaneous Equations - [Video 295](#)

353. Solve the simultaneous equations

$$2x + 4y = 26$$

$$3x - y = 4$$

$$x = \dots\dots\dots \quad y = \dots\dots\dots$$

354. Solve the simultaneous equations

$$3x + 2y = 16$$

$$2x - 3y = 2$$

$$x = \dots\dots\dots \quad y = \dots\dots\dots$$

355. Three bananas and two pears cost 95p.
Five bananas and three pears cost £1.51

Find the cost of ten bananas and ten pears.

£.....

Tally Charts - [Video 321](#)

356. Dara has recorded how many tries he scored in 25 rugby matches
Complete the tally chart

1	2	0	0	1
0	1	0	2	0
0	3	0	1	0
0	1	2	1	2
0	1	1	1	0

Number of tries	Tally	Frequency
0		
1		
2		
3		

Frequency Trees - [Video 376](#)

357. Complete the frequency tree.

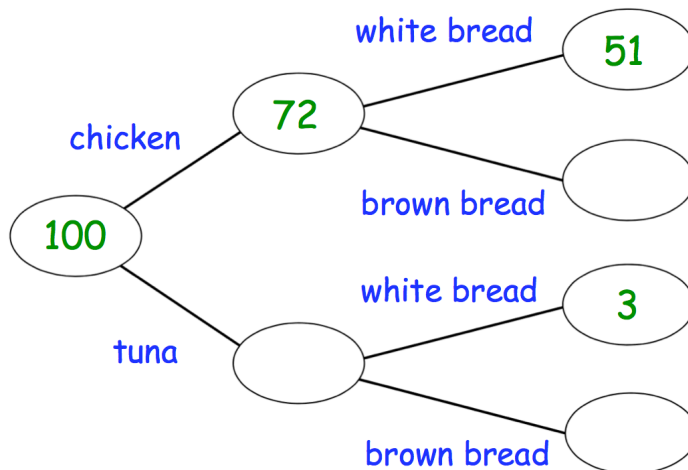

Two-way Tables - [Video 319](#)

358. Complete the two-way table.

	T-shirts	Jumpers	Coats	Total
Small	2	36	28	
Medium		0	1	10
Large		51		
Total			44	200

Pictograms - [Videos 161, 162](#)

359. The pictogram shows information about the amounts of money raised for charity by 4 friends.

Ben	○ ○ ○ ○ ◐
Cara	○ ○
Dylan	○ ○ ◐
Ellie	○ ○ ○ ○ ○

Key ○ represents £10

How much money was raised in total?

£.....

Bar Charts - [Videos 147, 148, 148b](#)

360.

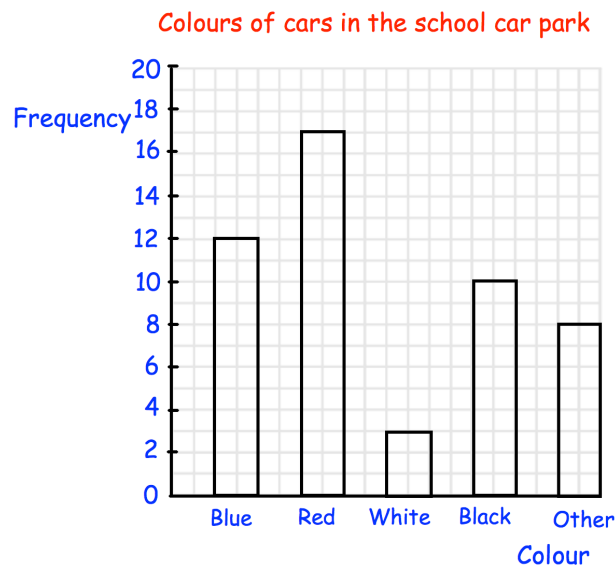

How many more red than white cars were in the car park?

Dual Bar Charts - Video [148b](#)

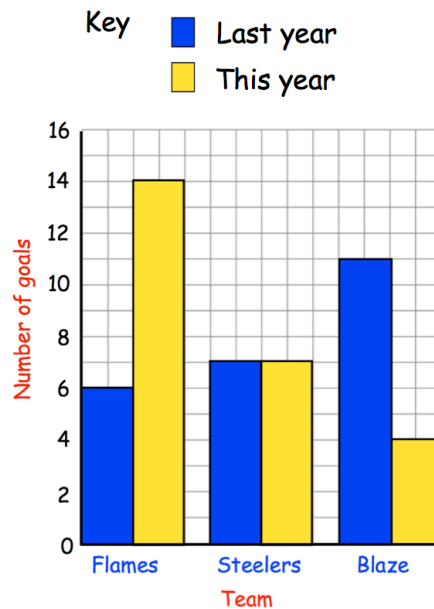

361. Which team scored the same number of goals in the cup this year and last year?

Composite Bar Charts - Video [148b](#)

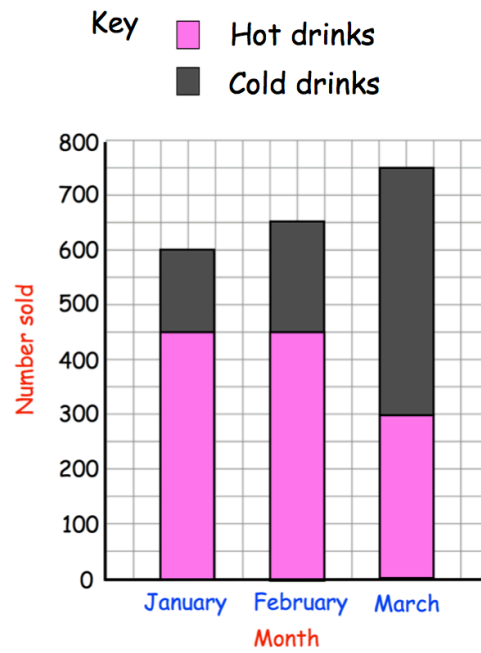

362. How many cold drinks were sold in total over 3 months?

Frequency Polygons - [Videos 155, 156](#)

363. Draw a frequency polygon to represent the data in the table.

Distance (miles)	Frequency
$0 < d \leq 2$	20
$2 < d \leq 4$	10
$4 < d \leq 6$	11
$6 < d \leq 8$	4
$8 < d \leq 10$	3

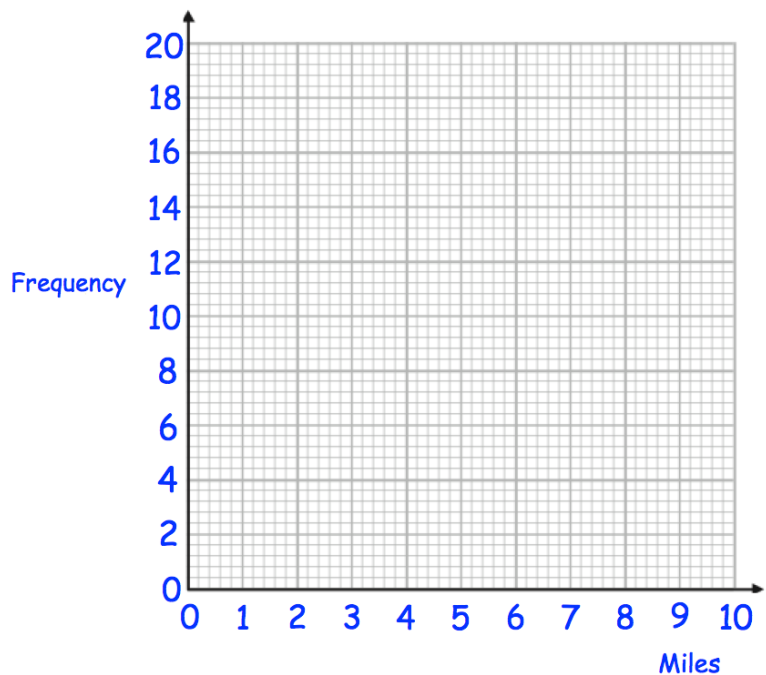

Line Graphs - [Video 160](#)

364. Complete the line graph.

	Belfast
Monday	14°C
Tuesday	16°C
Wednesday	15°C
Thursday	10°C
Friday	9°C

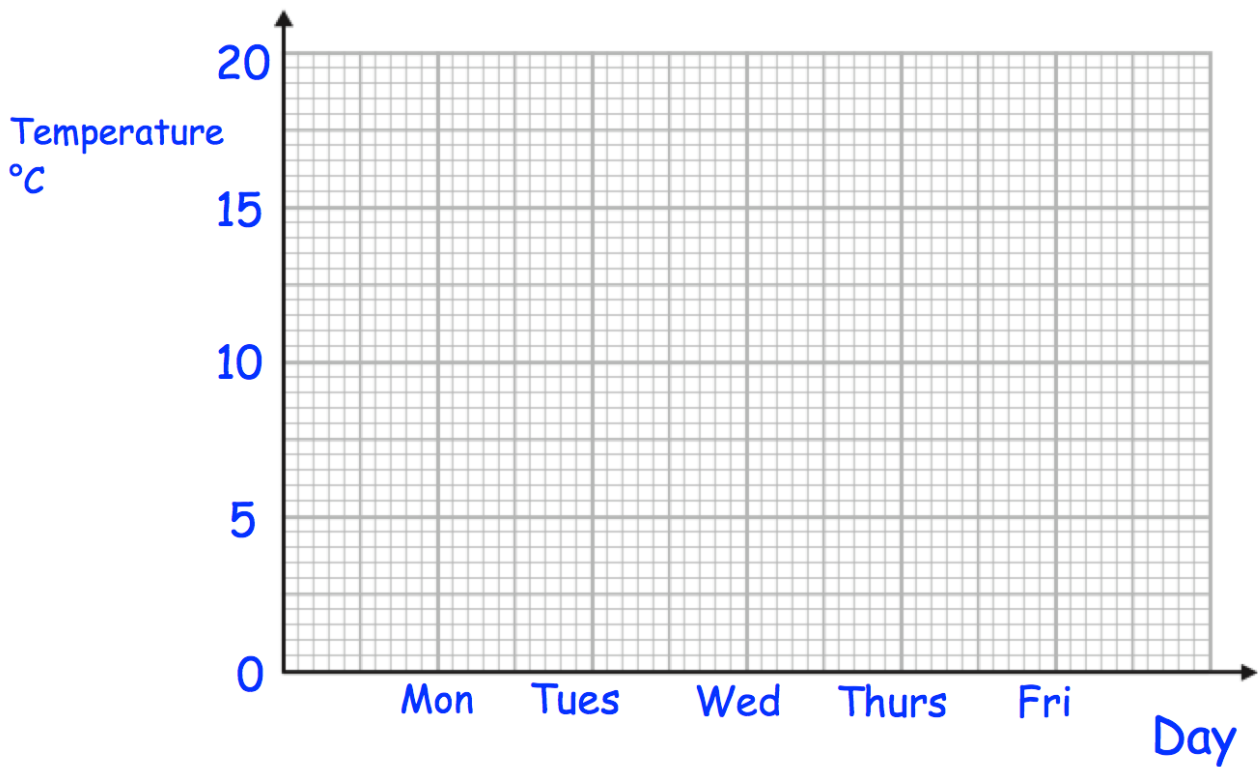

Pie Charts - [Videos 163, 164](#)

365. Sixty beads are placed in a box.

Draw a pie chart to represent the colours of the beads in the box.

Colour	Frequency
Blue	25
Green	14
Red	21

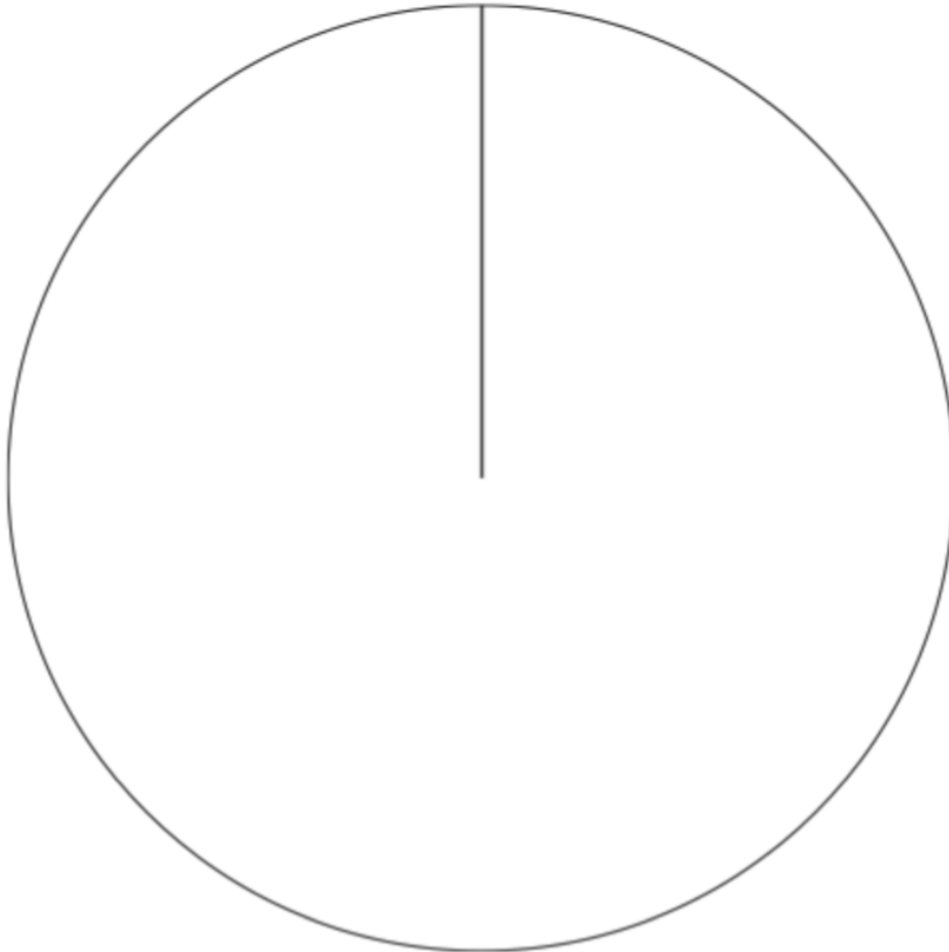

Probability Scale - [Video 251](#)

366. A fair spinner has 6 equal sections.

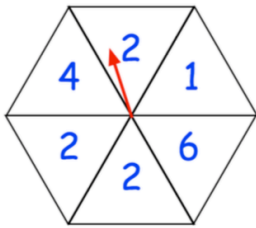

Impossible Unlikely Even Likely Certain

Which word from the box best describes the likelihood of each of the following

The arrow landing on an even number

.....

The arrow landing on 4

.....

The arrow landing on the number 2

.....

Probability - [Video 245](#)

367. There are 12 red roses, 5 yellow roses and 3 white roses in a vase.

Felix takes a rose, at random, from the vase.

Write down the probability that he takes a white rose

.....

Write down the probability that he takes a red or white rose

.....

Not Happening - [Video 250](#)

368. On a day in December, the probability of it snowing is 0.3

What is the probability of it **not** snowing?

.....

Relative Frequency - [Video 248](#)

David and Becky want to estimate how many yellow jelly beans are in a tub.

A trial consists of taking a jelly bean at random, noting the colour, and replacing the jelly bean in the tub.

	Number of trials	Number of yellow jelly beans chosen
David	20	3
Becky	100	11

369. Write down the relative frequency of David taking a yellow jelly bean.

.....

370. Write down the relative frequency of Becky taking a yellow jelly bean.

.....

371. Whose experiment gives the more reliable results?
Give a reason for your answer.

.....

.....

Listing Outcomes - [Video 253](#)

372. A fair spinner has four sections.

The spinner is spun twice.

The two numbers are added together to get a final score.

List all the possible final scores.

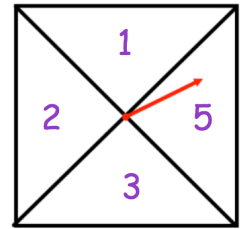

.....

.....

Sample Spaces - [Video 246](#)

Emily uses two fair spinners in a game.

She spins both spinners and she multiplies the two numbers together.

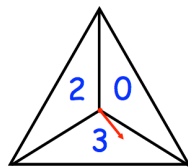

Spinner 1

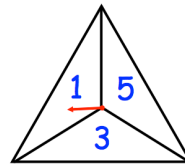

Spinner 2

		Spinner 1		
		0	2	3
Spinner 2	1			
	3			
	5			

373. Complete the table to show all possible outcomes.

374. Find the probability that her answer is greater than 5.

.....

Scatter Graphs - [Videos 165 to 168](#)

375. The scatter graph shows information about the cost of renting apartments and their distance from London.

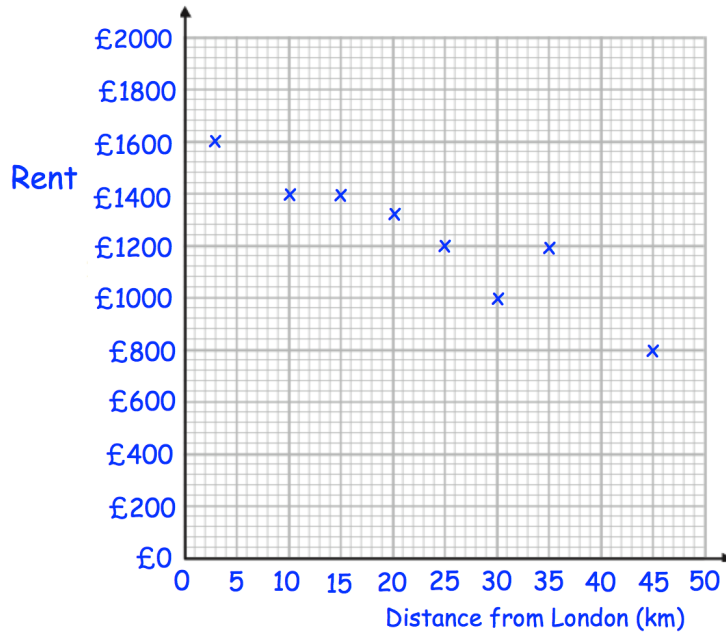

What type of correlation is shown?

.....

Estimate the cost of renting an apartment 40km from London.

£.....

Stem-and-Leaf - [Videos 169, 170](#)

376. The stem and leaf diagram shows the heights of 14 friends visiting a theme park

Key: 13|5 means 135cm

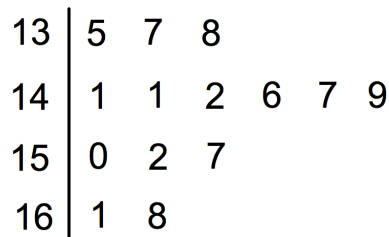

What fraction of the friends have a height greater than 1.4m?

.....

Mode - [Video 56](#)

377. Write down the mode

5 9 3 4 5 1 9 5 8 7

.....

Median - [Video 50](#)

378. Find the median

12 7 11 14 15 19

.....

Mean - [Video 53](#)

379. Work out the mean

9 8 15 24

.....

Ranges - [Video 57](#)

380. Work out the range

9 8 15 24

.....

Mode from a Frequency Table - [Video 56a](#)

381. The table shows the number of apples eaten one day by 40 people.

Number of apples	Frequency
0	11
1	14
2	8
3	7

Write down the modal number of apples eaten.

.....

Mean from a Frequency Table - [Video 54](#)

382. The table shows the number of apples eaten one day by 10 people.

Number of apples	Frequency
0	2
1	2
2	5
3	1

Work out the mean number of apples eaten.

.....

Median from a Frequency Table - [Video 51](#)

383. The table shows the number of apples eaten one day by 9 people.

Number of apples	Frequency
0	3
1	4
2	1
3	1

Work out the median number of apples eaten.

.....

Estimated Mean - [Video 55](#)

384. Work out an estimate for the mean length.

Length (cm)	Frequency
$0 \leq L < 30$	8
$30 \leq L < 60$	43
$60 \leq L < 90$	25
$90 \leq L < 120$	4

.....

Modal Class - [Video 56a](#)

385. Write down the modal class interval.

Length (cm)	Frequency
$0 \leq L < 30$	8
$30 \leq L < 60$	43
$60 \leq L < 90$	25
$90 \leq L < 120$	4

.....

Class containing Median - [Video 52a](#)

386. Which class interval contains the median?

Length (cm)	Frequency
$0 \leq L < 30$	8
$30 \leq L < 60$	43
$60 \leq L < 90$	25
$90 \leq L < 120$	4

.....

Combined Mean - [Video 53a](#)

387. There are 40 houses in *Greenvale* and 60 houses in *Redville*.

The mean number of cars per house in *Greenvale* is 1.5

The mean number of cars per house in *Redville* is 3

Work out the mean number of cars per house in both villages.

.....

Venn Diagrams - [Video 380](#)

388. Jennifer asked 80 people which sports they enjoy from football, hockey and rugby.

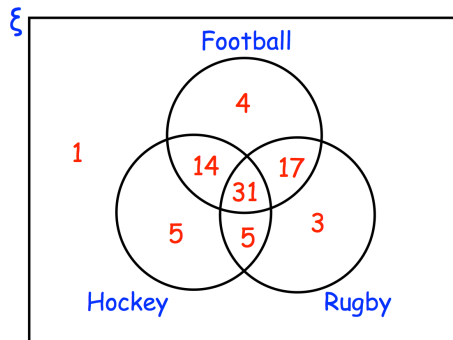

How many people enjoy all three sports?

.....

How many people enjoy football and rugby but not hockey?

.....

389. $\xi = \{1, 2, 3, 4, 5, 6, 7, 8, 9\}$

$A = \{1, 5, 7, 9\}$

$B = \{3, 7, 9\}$

Complete the Venn diagram

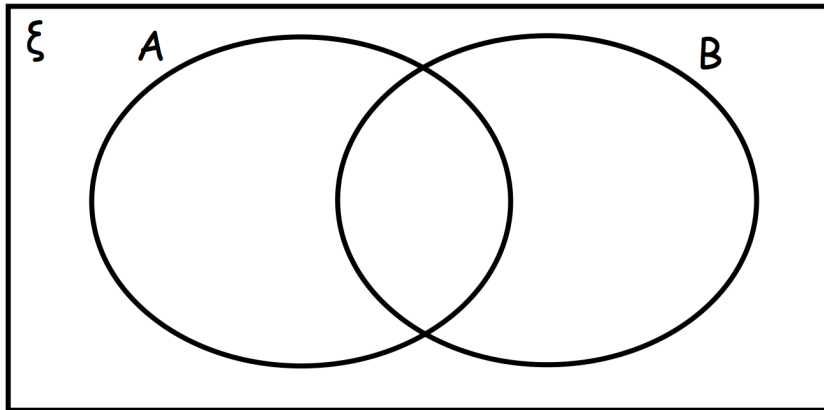

A number is chosen at random, find the probability of:

390. $P(A')$

.....

391. $P(A \cup B)$

.....

392. $P(A \cap B)$

.....

Tree Diagrams - [Video 252](#)

Siobhan has 10 socks in a drawer.

6 socks are black and 4 socks are white.

She picks a sock at random, puts it back and then takes out a second at random.

393. Complete the tree diagram.

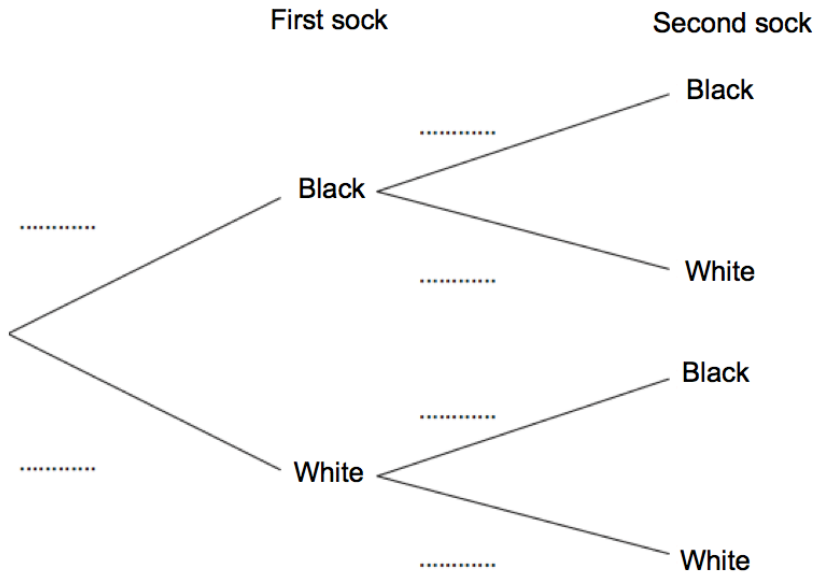

394. Work out the probability that the two socks are both white.

.....

395. Work out the probability that the two socks are the same colour.

.....

396. Work out the probability that the two socks are different colours.

.....

Reading Tables - [Video 387](#)

Name	Price (£)	Mass (kg)	Thickness (cm)	Battery (minutes)
Epic	£799	1.23	1.89	690
Bell	£1249	1.2	1.52	650
Lemon	£1599	1.37	1.49	720
HB	£799	1.28	1.7	740
Lazer	£1049	1.35	1.66	660

397. Which laptop is the thinnest?

.....

398. How much longer does the HB battery last than the Lazer battery?

.....

Samples - [Video 281a](#)

Mrs Martin wants to open a new restaurant in her town.
She wants to find out what type of food people in her town like.

399. Caolán suggests that she posts a survey to 100 people chosen at random across the country.

Explain why this is not sensible.

.....

.....

400. Jack suggests that she surveys 5 people in the town centre.

Explain how Jack's suggestion could be improved.

.....

.....